

## 가스사출성형에서의 가스흐름방향을 예측하기 위한 경험법칙과 표준

홍수현, 임광희\*  
대구대학교 화학공학과  
(khlm@daegu.ac.kr)

### Rule of thumb and its Criterion to predict gas flow directions in gas assisted injection molding

Soo-Hyeun Hong, Kwang-Hee Lim\*  
Daegu University Department of Chemical Engineering  
(khlm@daegu.ac.kr\*)

#### INTRODUCTION

Mold-design should be performed for gas to flow to the intended directions in the gas-assisted injection molding (GAIM). If gas goes in a wrong direction, many problems occur including a phenomenon called "blow through" and another phenomenon called "penetration into thin walled region". If the gas does not enter where it is expected, a problem like sink mark occurs. The control of gas direction is thus one of the most critical aspects in the application of the technology.

The rule of thumb on the direction of gas flow for GAIM has been investigated [Lim and Soh, 1999; Soh, 2000; Soh and Lim, 2002; Lim and Lee, 2003; Lim, 2004a, 2004b; Lim and Hong, 2004] and simulation packages were used to verify the gas direction predicted by the rule of thumb. Lim and Soh [1999] assumed that pressure difference between a gas injection point and appropriate vent areas at both sides of well-maintained molds are equal. Consequently the pressure drops at both sides are equated to compare the resistances and to predict the gas direction. If the resistance in the sentence of "Gas goes to the direction of the least resistance" is the resistance to flow rates, this statement is not always correct. The resistance to flow rates cannot be a criterion in the prediction of gas flow direction in GAIM. Soh [2000] qualitatively treated the special case that the same resistances to flow rates for both sides resulted in the same flow rates for both sides under the geometry that two same set of two different pipes connected in series are located in parallel. Soh and Lim [2002] suggested the definition of the resistance to velocity to predict the gas-preferred direction under the simplest geometry of two different pipes connected at one connection point. However if more complicated geometries are involved, the change of velocity of melt resin becomes unavoidable. Therefore Lim and Lee [2003] established more developed-precise definition of the resistance to velocity as a rule of thumb.

Furthermore Lim [2004a, 2004b] suggested a flow model theory and its criterion under the geometry of fan-shapes between flat plates and introduced a developed flow model under the geometry of pipes in gas assisted injection molding, respectively. Lim and Hong [2004] developed the flow model under

the geometry of fan-shapes between flat plates. In this paper various rule of thumbs and flow models shall be introduced and integrated.

## METHODS

### 1. Theory

The steady state flow of a pseudo plastic liquid through conduit with the radius of  $R$  is given by

$$\frac{\Delta P}{2L} = \left( \frac{Q(3n+1)}{\pi n} \right)^n \left( \frac{m}{R^{(3n+1)}} \right) \quad (1)$$

where

- $m, n$  = power law indices
- $L$  = length of pipe in direction of flow
- $R$  = pipe radius excluding frozen layers adjacent to mold surface
- $\Delta P$  = pressure drop across the distance

It is suggested that a pseudo-plastic fluid through conduit may be treated as a Newtonian fluid in such a qualitative approach as the rule of thumb to determine gas direction in GAIM. The expression of pressure drop of the steady state flow of a Newtonian liquid through a conduit with diameter of  $D$  is given in terms of average velocity  $V$  as Eq. (2) by McCabe *et al.* [1986]

$$\Delta P = \frac{32\mu VL}{D^2} \quad (2)$$

Eq. (2) may be rewritten in terms of flow rate  $Q$  as

$$\Delta P = \frac{128\mu LQ}{\pi D^4} \quad (3)$$

On the other hand, under the geometry of fan-shaped cavity between two flat plates, the expression of melt phase flow rate may be obtained as:

$$Q = \hat{\theta} r H \langle v_r \rangle = 2 \int_0^{\hat{\theta}} v_r(r, z) \hat{\theta} r dz = \frac{2 \hat{\theta} h^3}{3 \mu \ln \frac{R_0}{R_1}} \frac{P_1 - P_0}{H} \quad (4)$$

where  $\langle v_r \rangle$ : average velocity of melt phase flow

Eq. (4) may be rearranged as:

$$\Delta P_{\text{fan-plates}} = \frac{12\mu Q}{H^3 \hat{\theta}} \ln \frac{R_0}{R_1} = Q \frac{12\mu}{H^3 \hat{\theta}} \ln \frac{R_0}{R_1} \quad (5)$$

### 2. Resistance of four conduits with same length and different diameter connected in series and parallel as well as a cavity of

In such a complex situation as runners or thick cavity of two square plates connected to cavities composed of four pipes with same length and different diameter connected in series and parallel, a developed concept of a criterion in the prediction of gas flow direction of GAIM may be proposed as the resistance to the initial velocity of melt polymer at the nearest geometry to a gas injection point. (Figs. 1 and 2)

Figure 3 show a simple panel part with a gas channel where a pipe is connected to a fan-shaped cavity with a vertex angle of  $\pi$ , formed by two parallel plates and gas is injected at the part above where two cavities are connected.

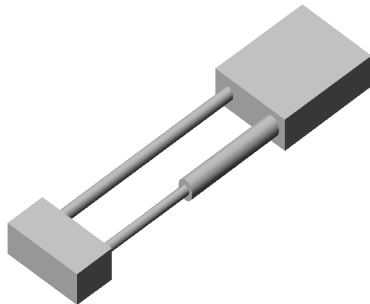

Fig. 1

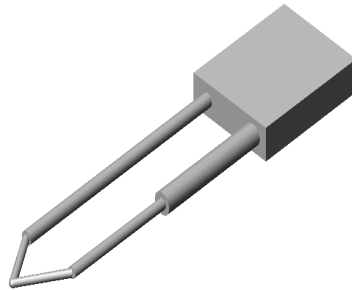

Fig. 2

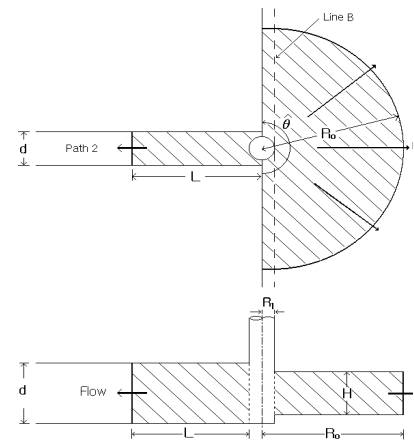

Fig. 3

### 3. Definition of proposed resistance

The definition of resistance may be developed and proposed to be  $\Omega^*$  of a resistance to the initial velocity of melt polymer at the nearest geometry to a gas injection point while the resistance to flow rate ( $\Omega$ ) was previously defined. On the other hand, the definition of resistance under fan-shaped geometry may be proposed as:

$$\frac{r^*}{r^{*'}} = \frac{H^2 R_0}{H^2 R_0'} \frac{\ln \frac{R_o}{R_1}}{\ln \frac{R_o'}{R_1'}} \quad (6)$$

where a prime (') denotes the right hand side of two fan-shaped cavities.

## RESULTS AND DISCUSSION

Figure 4 shows a simulation result of commercial software, Moldflow, that is consistent to the prediction that the gas did not pass through pipe 2 but through pipe 1. All the white region represent the cavity with 100 % polymer, and the colored regions represent the cavity where gas entered. The gas time in colored region shows the time when the gas was reached. The ratio of the resistances to flow rate ( $\Omega_2/\Omega_1$ ) of Fig. 4 becomes less than the ratio of the resistances to initial resin velocity ( $\Omega_2^*/\Omega_1^*$ ). However both ratios are greater than unity.

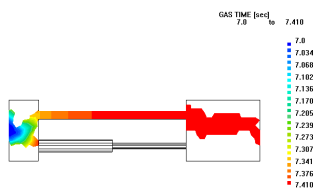

Fig. 4

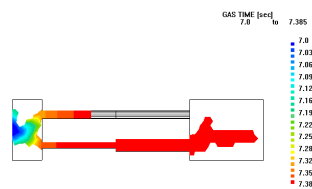

Fig. 5

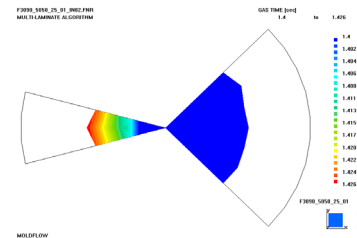

Fig. 6

When the same pipes are used and the lower pipes are flipped horizontally, the ratio

of the resistances to flow rate ( $\Omega_2/\Omega_1$ ) becomes greater than unity. However the ratio of the resistances to initial resin velocity ( $\Omega_2^*/\Omega_1^*$ ) becomes less than unity. Figure 5 shows a simulation result of commercial software, Moldflow. The simulation result is consistent to the result of rule of thumb using the ratio of the resistances to initial resin velocity ( $\Omega_2^*/\Omega_1^*$ ). Thus one should not use the resistance to resin flow rate but use the resistance to initial velocities to predict the gas direction since the gas bubble is first seen in the direction of higher velocity. This case shows an example where the least resistance to initial resin velocity should be a required condition to determine the gas flow directions instead of that to flow rates. Figure 6 shows the simulation result of Moldflow, which shows the length of gas penetration to both direction under fan-shaped geometry. The ratio of resistances becomes 6.3, which means the gas flow direction of the right. Thus the result of the proposed rule of thumb was consistent with the simulation results.

## CONCLUSION

The gas path was predicted to change by flipping the lower side pipes, pipe 2, which was consistent to the result of simulation. Neither the flow rate ratio nor the ratio of resistances to flow rates can be a criterion in the prediction of preferred direction of gas. The resistance to initial resin velocities should be a criterion in the prediction of preferred direction. For various geometries including pipes and fan-shape between two flat plates, the rule of thumbs suggested were quite capable of predicting the direction of gas flow in gas assisted injection molding.

## REFERENCES

1. Lim, K. H. and Lee, E. J., "Prediction of gas flow directions in gas assisted injection molding when cavities and runners are involved," *Korean Journal of Chemical Engineering*, 20(3), 592 (2003).
2. Lim, K. H., "Flow direction when fan shaped geometry is applied in gas assisted molding: 1. Theory of flow model and its criterion to predict flow directions," *Korean Journal of Chemical Engineering*, 21(1), 48 (2004a).
3. Lim, K. H. and Hong, S. H., "Flow direction when fan shaped geometry is applied in gas assisted molding: 2. Development of flow model and its predictions," *Korean Journal of Chemical Engineering*, 21(1), 59 (2004).
4. Lim, K. H., "Gas flow direction under heterogeneous geometry composed of a pipe and a cavity of two square-flat plates in gas assisted injection molding," *Journal of industrial and engineering chemistry*, In review (2004b).
5. Lim, K. H., and Soh, Y. S., The diagnosis of flow direction under fan shaped geometry in gas assisted injection molding, *Journal of Injection Molding Technology*, 3, 31 (1999)
6. Soh, Y. S., and Lim, K. H., Control of gas direction in gas assisted injection molding ; Definition of resistance to velocity,  $r_{\bar{v}}$ , SPE ANTEC Tec. Papers, 60, 482 (2002)
7. Soh, Y. S., Control of gas direction in gas assisted injection molding, *Journal of reinforced plastics and composites*, 19, 955 (2000)