

Photochemical Techniques

홍익대학교
신동명

- Tungsten Lamp

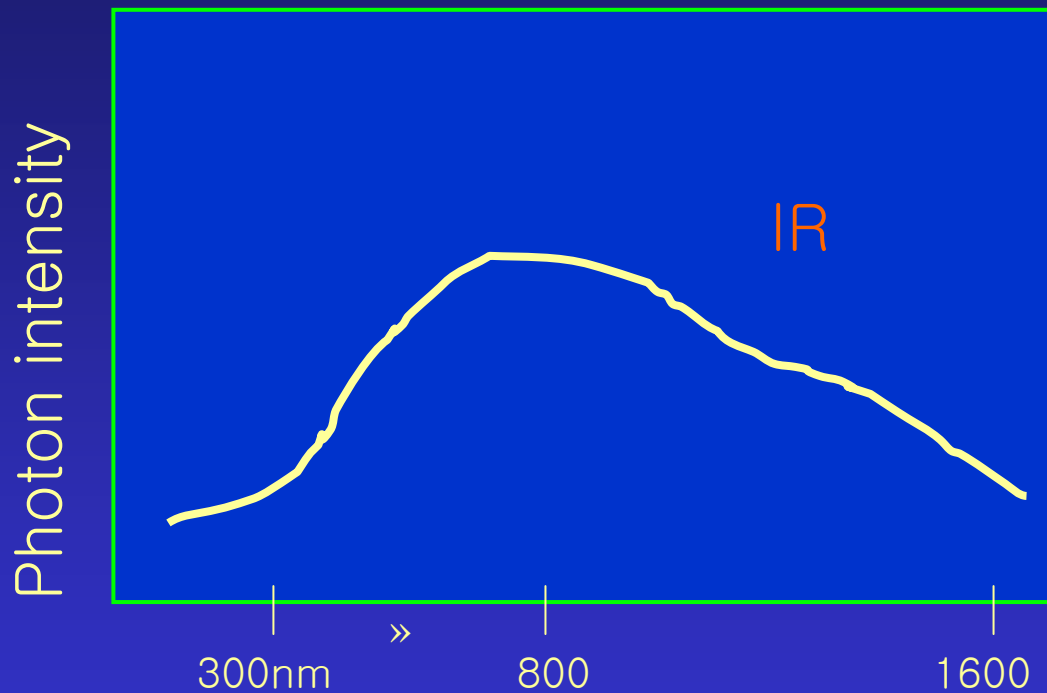

장점:

lamp 값 저렴
visible~IR region까지
broad continuous spect.

*눈으로 볼 땐 노란색

단점 :

UV region 거의 없다.

λ nm

• Tungsten-halogen Lamp

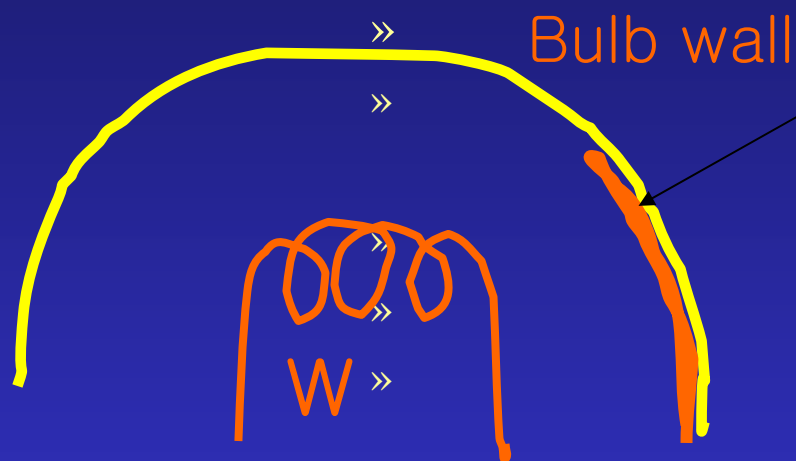

표면에
evaporated W + halogen

Halogen은 W가 가열되면서
filament에 떨어지게 한다.
(3000~3200 K 가능하게 한다.)

- » Bulb wall의 온도를 250°C로 유지시켜야 한다.
- » 온도를 높게 해주면 visible 쪽으로 shift
- (태양 표면 온도 6000°C => UV 영역의 빛이 많이 나온다.)

- Deuterium Lamps
- UV spectrophotometer의 light source
- 단점 low output

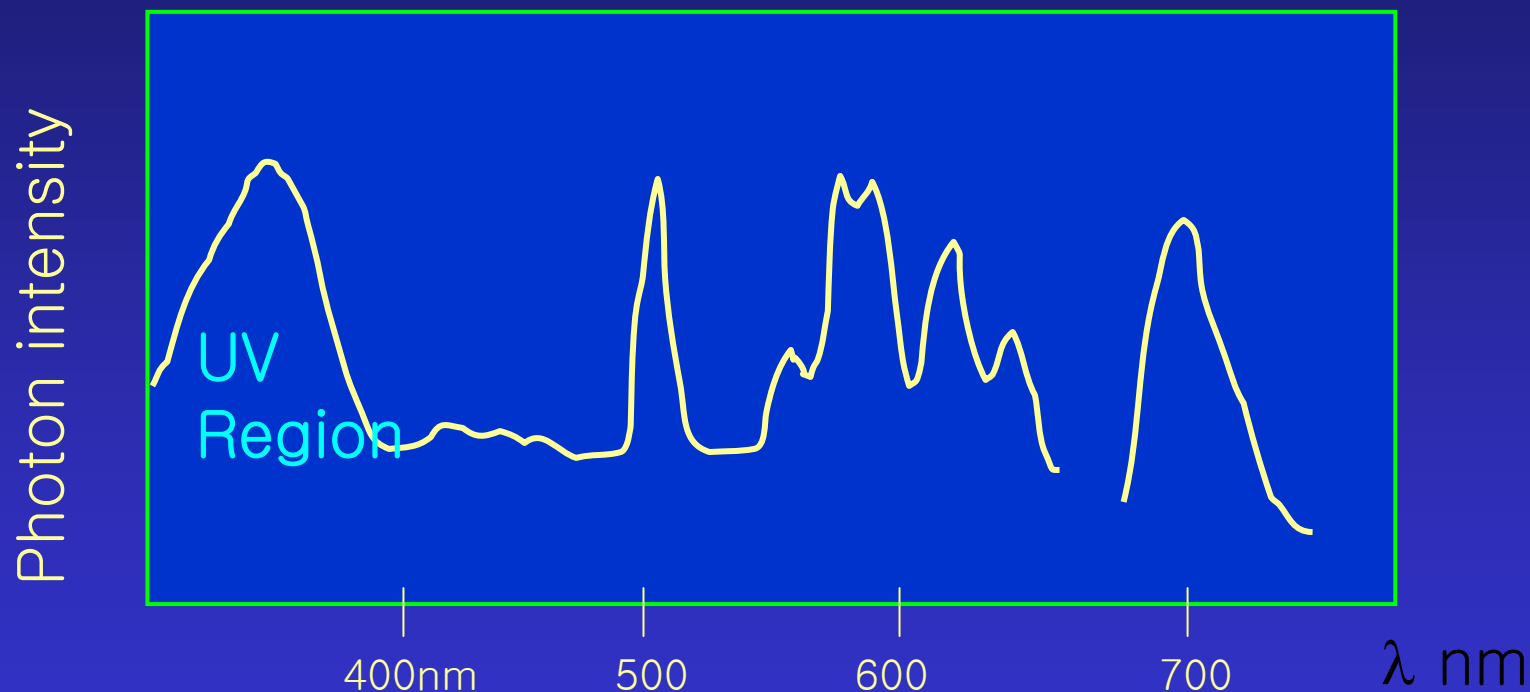

- 180nm ~ 350nm 영역 이용
- 350nm 근처에서 W 에서 D₂로 바꿔준다.

- Deuterium Lamps

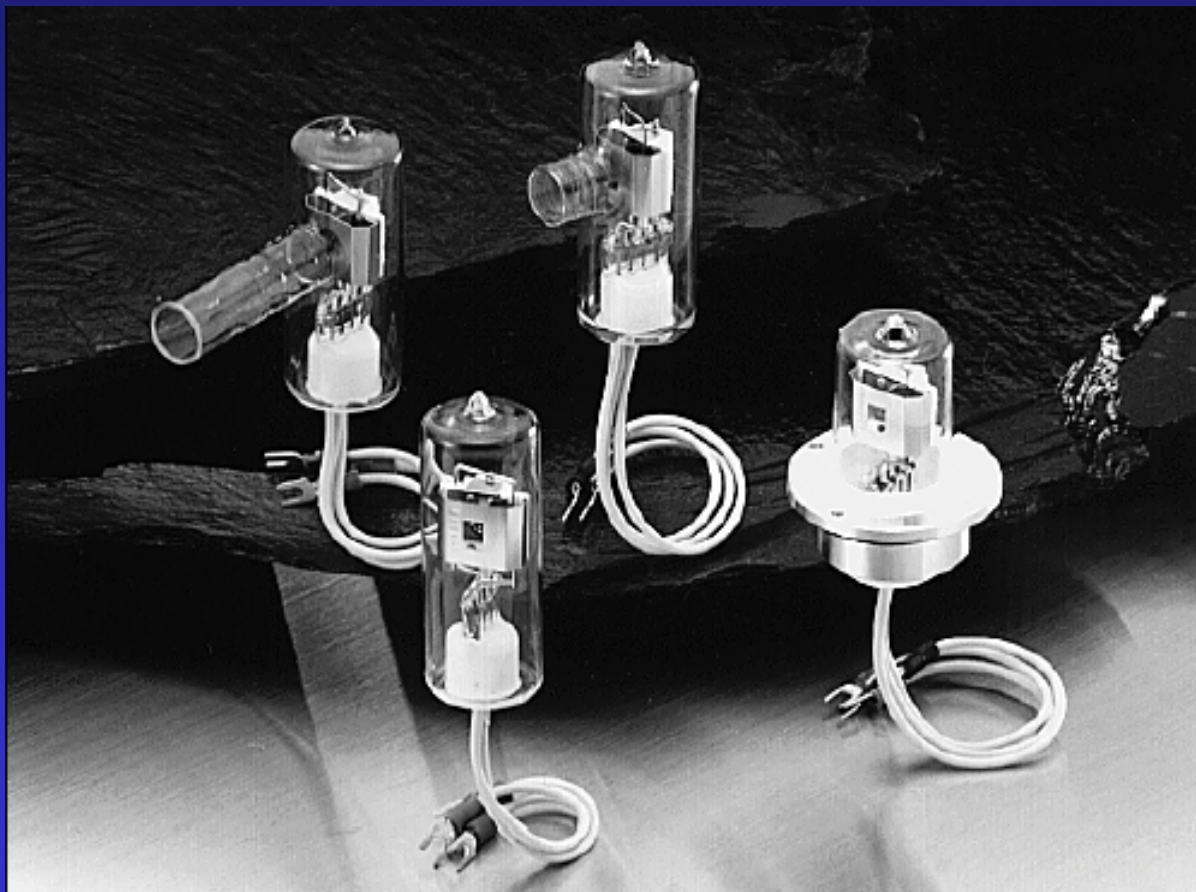

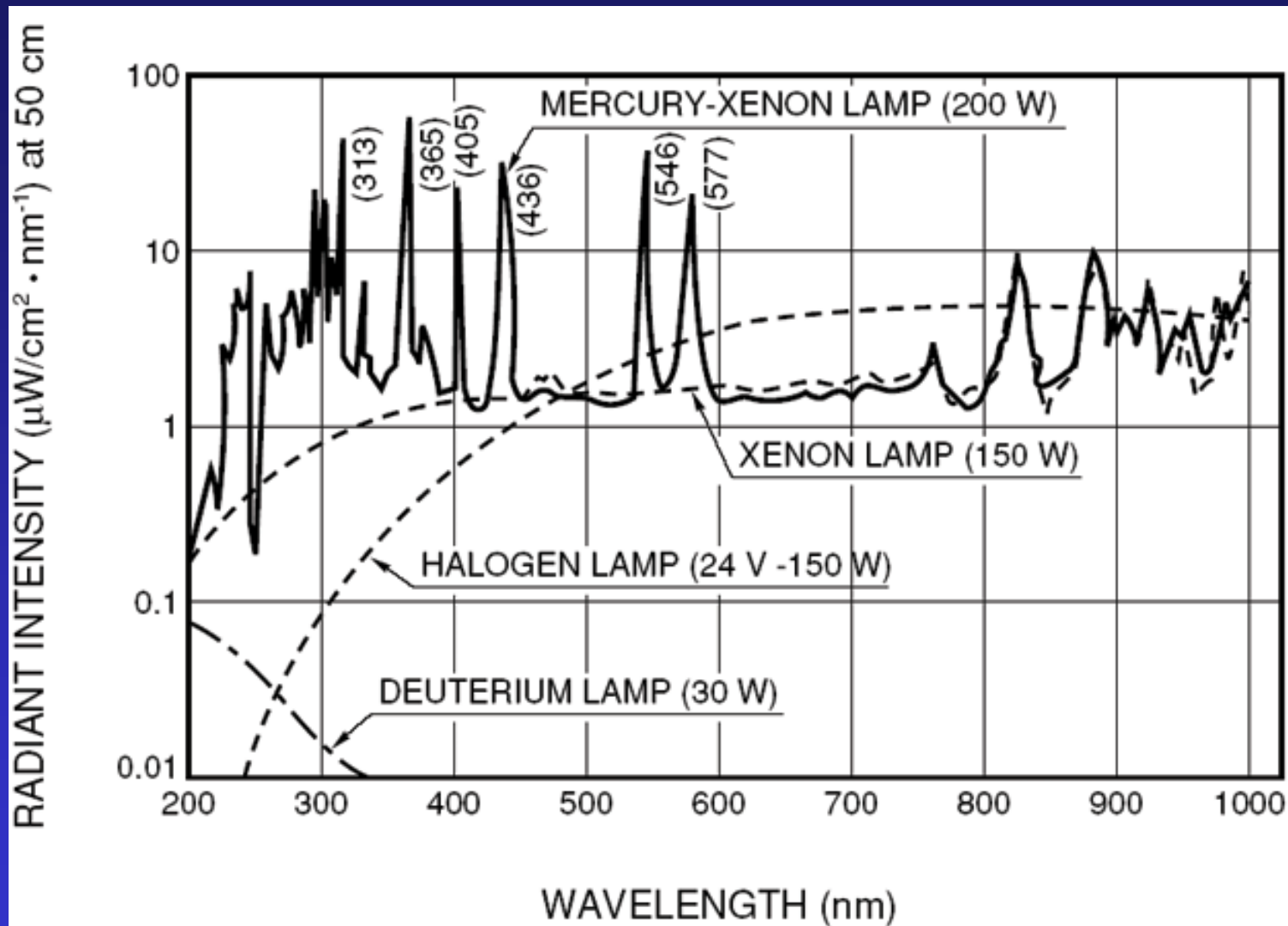

- 기존 UV-visible spectrophotometer

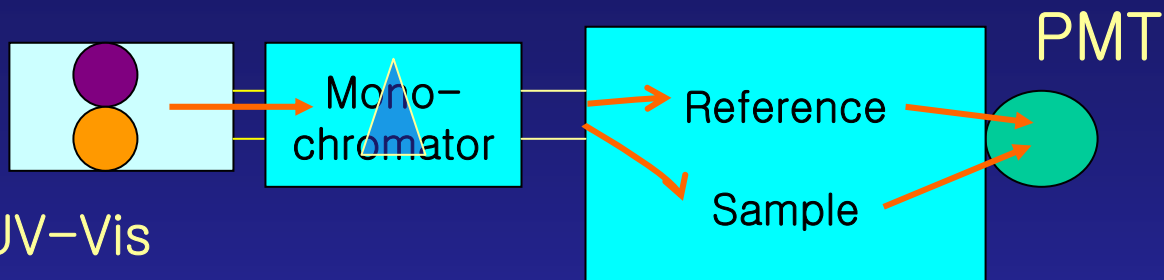

- UV-Vis light source

- Diode array type

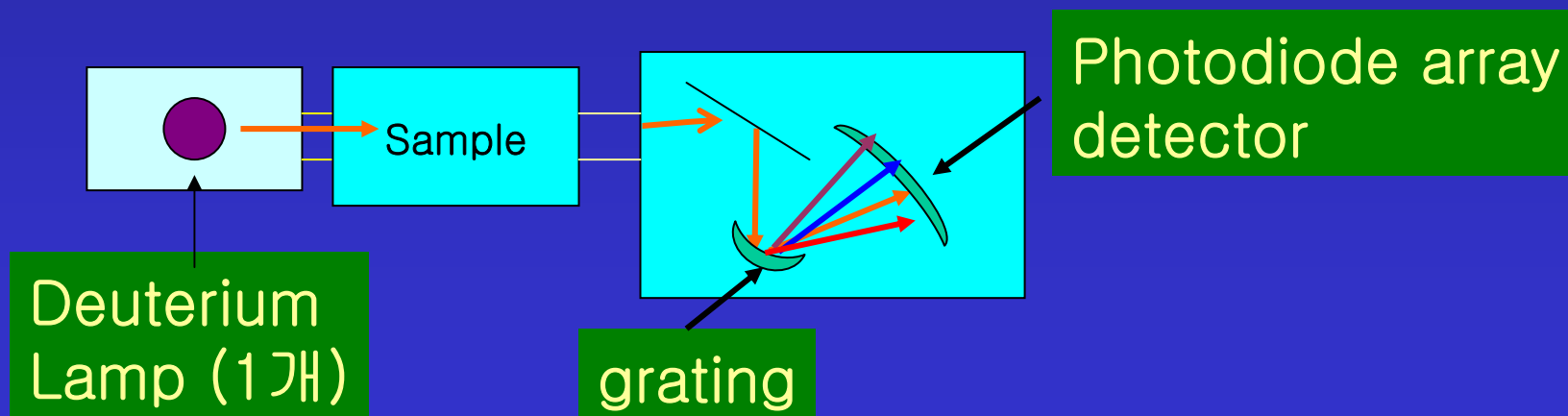

- Electrode 사이에 arc 를 만들어서, mercury를 여기시켜 빛 발생
 1. Low pressure : Hg vapor pressure $\sim 10^{-3}$ torr
(184.9nm, 253.7nm를 주로 이용)
 2. Medium pressure $\sim 1-1.3$ atm
 3. High pressure $\sim 100-400$ atm

Photochemical Technique: Xe-Mercury arc lamps

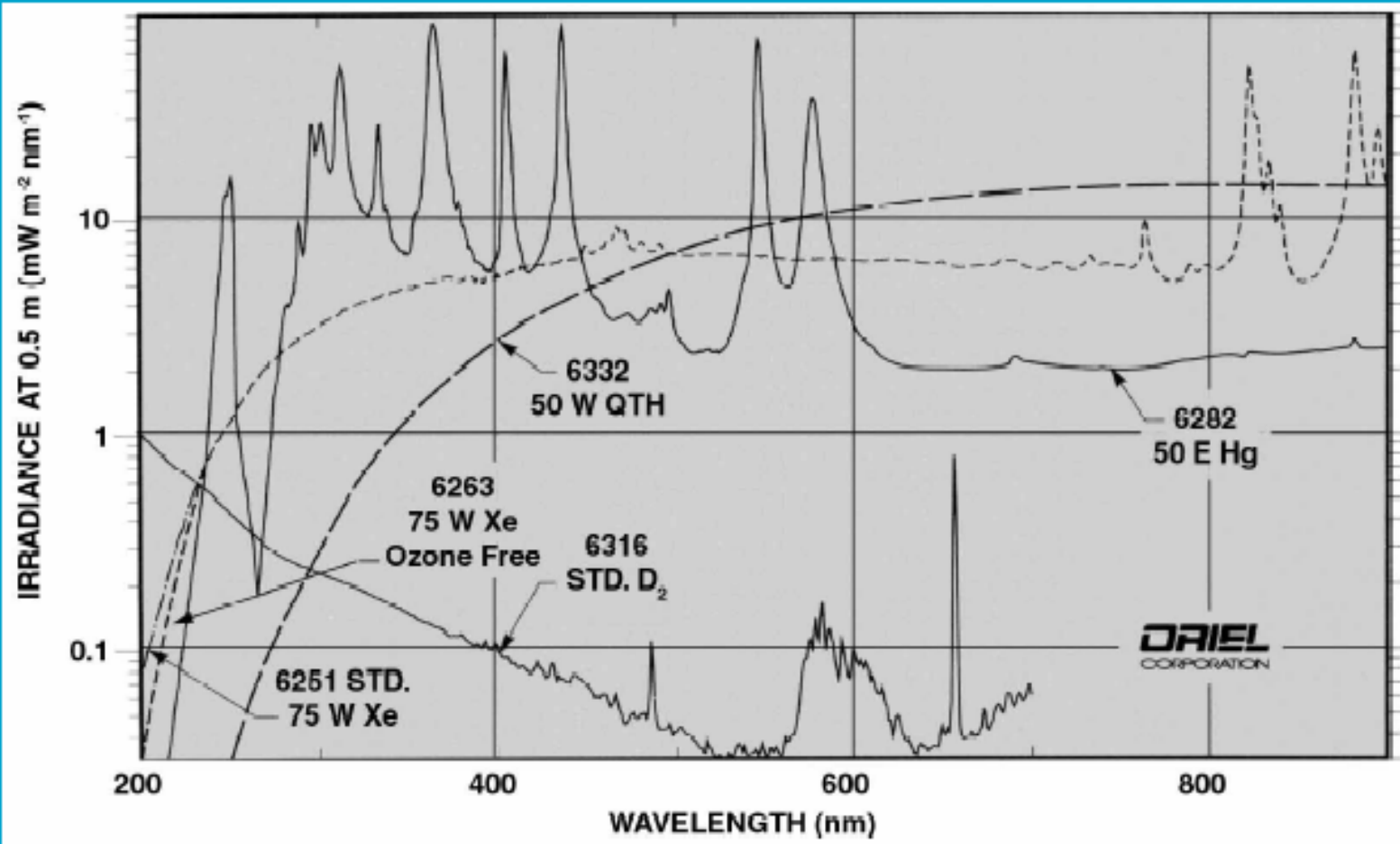

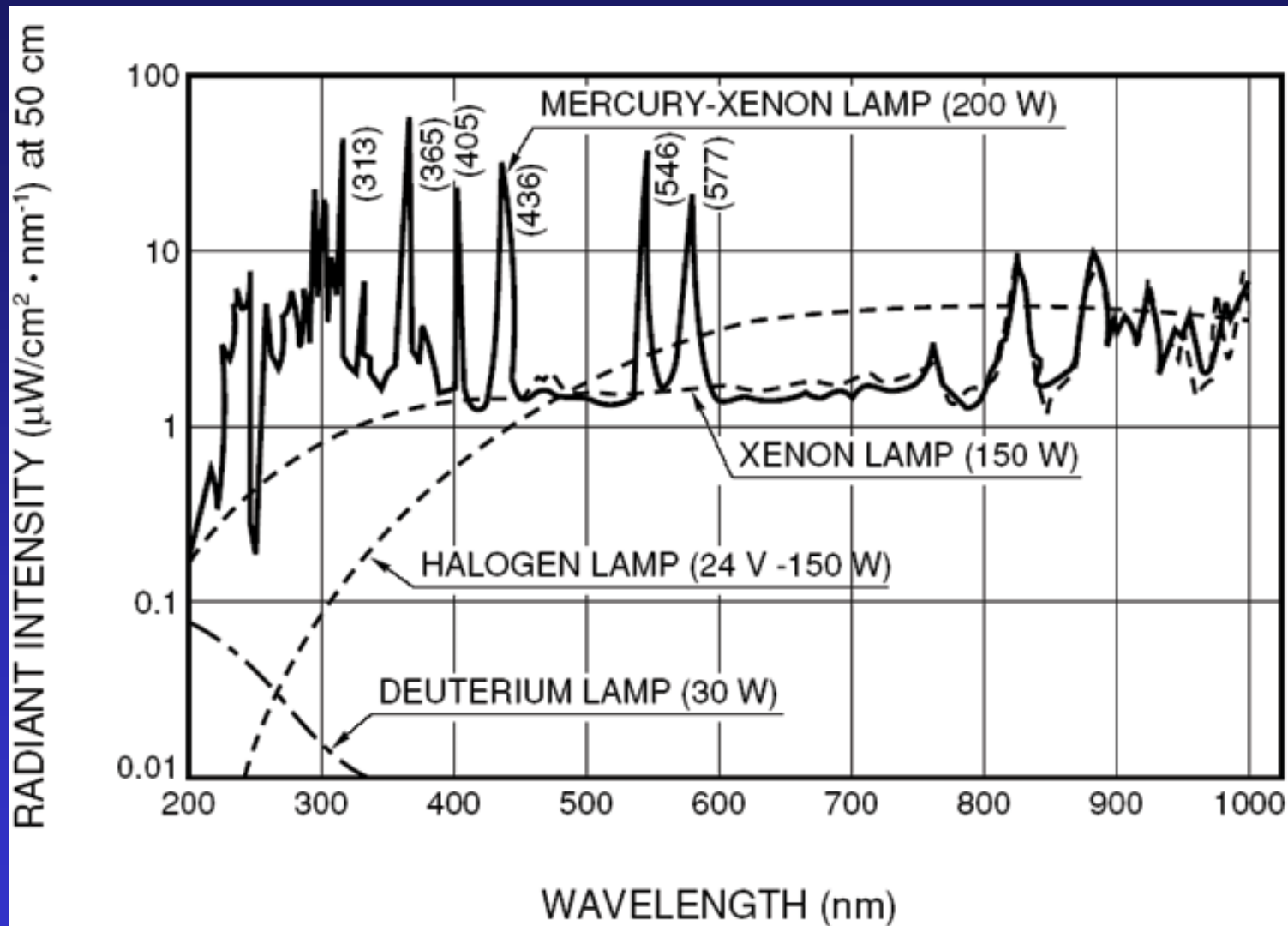

- Low Pressure Lamp – arc가 크다.
(arc 가 작을 수록 밝기가 밝다.)

파장	248.2 nm	253.7	265.2 ~ 265.5	275.3
상대강도	0.01	100	0.05	0.03
파장	280.4	289.4	296.7	302.2 ~ 302.8
상대 강도	0.02	0.04	0.2	0.06
파장	312.6 ~ 313.2	365.5 ~ 366.3	404.5 ~ 407.8	435.8
상대강도	0.6	0.54	0.39	1.0
파장	546.1	557~579	1014	1128.7
상대강도	0.88	10.1	-	-

- Grating 교정 (low pressure Hg lamp 또는 laser 사용)

- 유럽에서는 high pressure 라고 함.

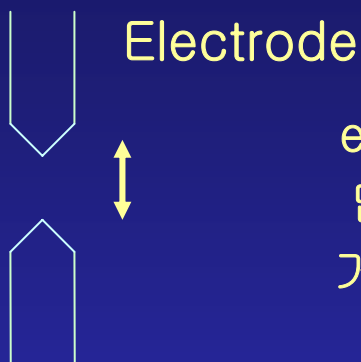

electrode 사이 거리가 많이 떨어져 있고, 에너지가 많이 들어간다.
거리가 100mm 이상인 것을 medium pressure lamp.

High pressure lamp는 medium prs. Lamp에 비해 압력이 높고 ($P \sim 20$ atm 이상), 온도 높고 전류 높다.

High pressure는 < 5 mm : power supply 가 상당히 크다.

(cf; capillary lamp : 10 ~ 30 mm)

용도: Photochemical reaction에서 UV region의 irradiation이 필요한 경우

- Operate at high pressure (20 atm)
- Start arc.
- Focusing 하면 종이가 탄다. -> ir filter를 사용

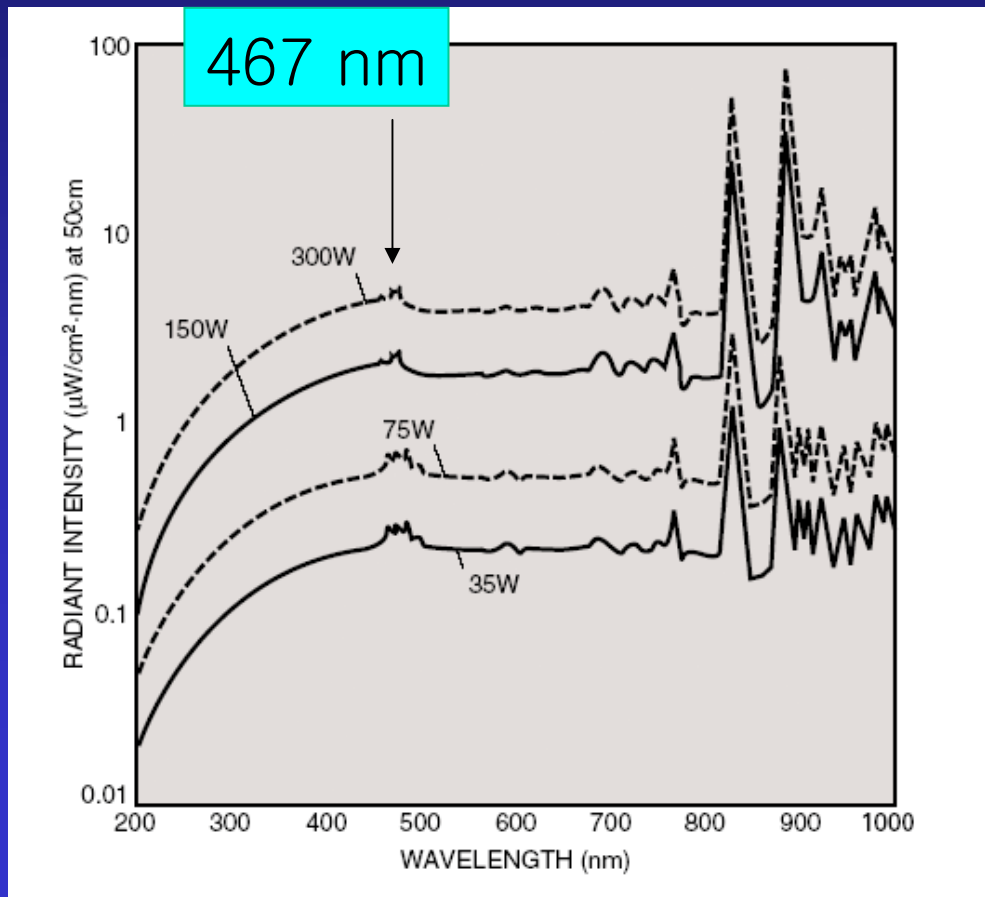

1. Radiant Power (Flux) unit: W ; radiation energy (in joule) / time
2. Luminous Power (Flux) unit : lm ; radiant power modified by the response of the human eyes (주로 visible)
3. S/N ratio (signal current/noise current, or voltage) 클수록 좋다.
4. Noise Equivaent Power (NEP) : noise 와 같은 level의 signal을 만드는데 필요한 radiant power.
5. Detectivity $D = 1/NEP$
6. Spectral response : plot of the radiant sensitivity for wavelength
7. Quantum efficiency : # of electrons / # of photons (1개 photon 이 들어와서 1개의 electron 이 만들어지면 $q.e = 1$)
8. Rise time : the time for a detectoer signal to rise from 10 % go 90 % of peak amplitude for illumination with a delta function light pulse

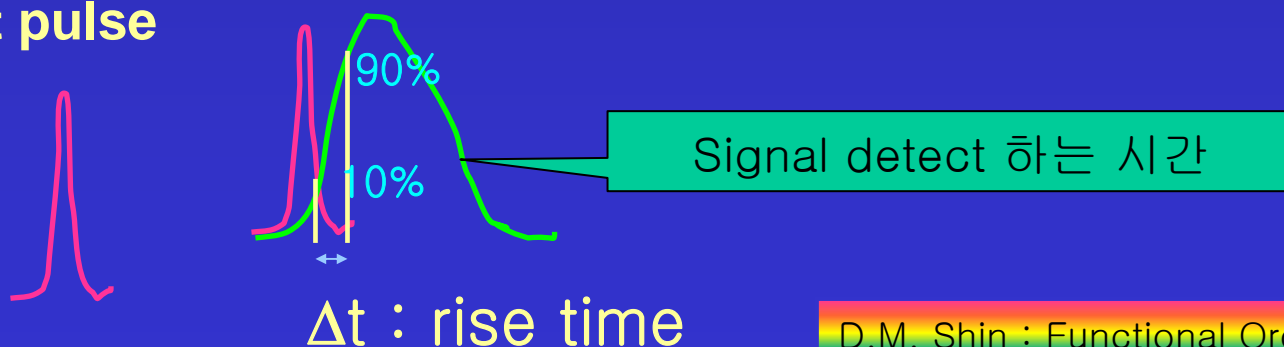

1 photoelectron \rightarrow 4 secondary electrons / Dynode
Head-on PMT

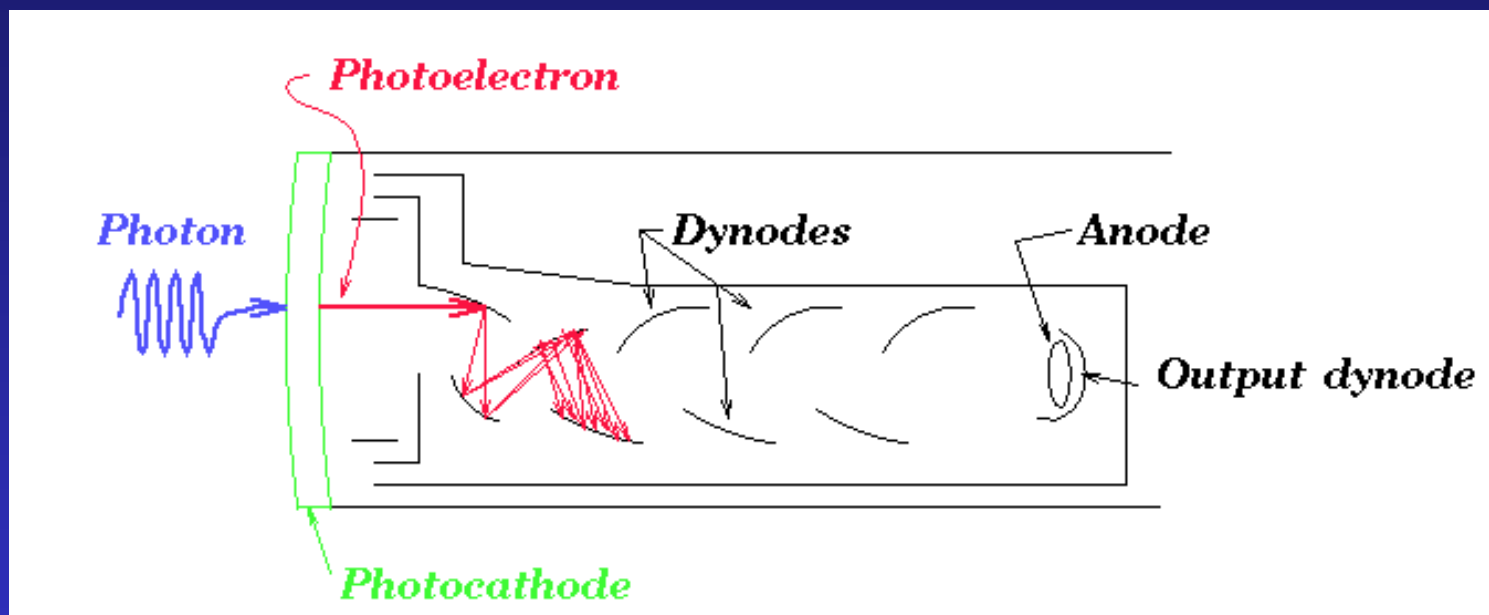

Side-on PMT

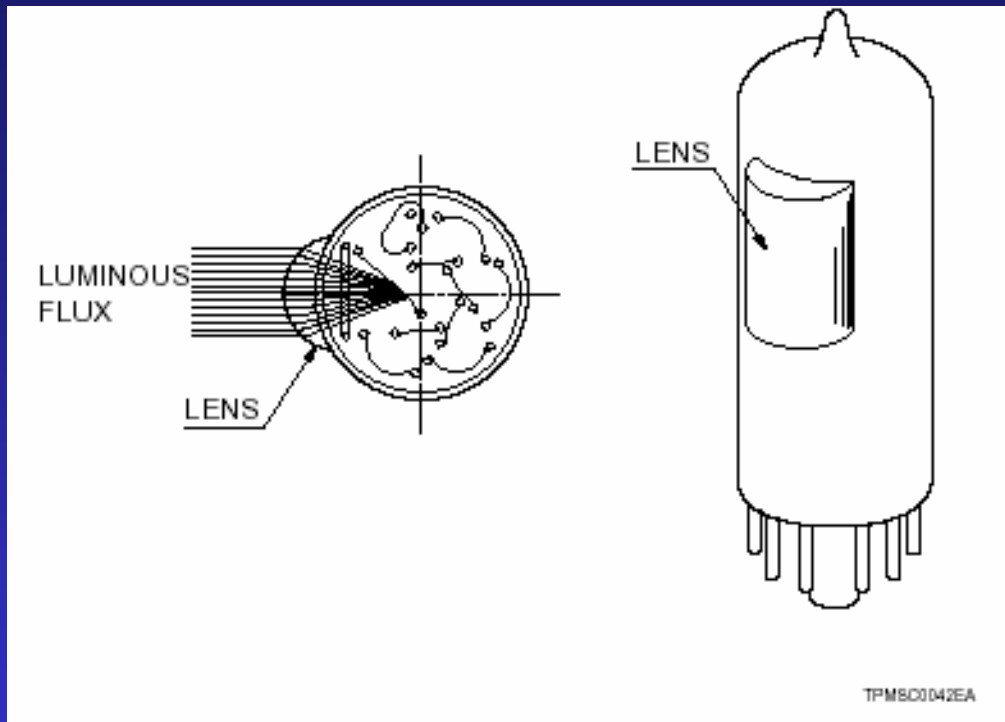

PMT의 response sensitivity는 stage 개수에 따라 결정
Secondary electron은 quantum efficiency에 따라 나오는 양이 다르다.
이것이 다른 cathode 를 때려서 electron이 증가된다. (10^8 배 /14dynode)

Spectral Response – PMT 종류에 따라 다름.

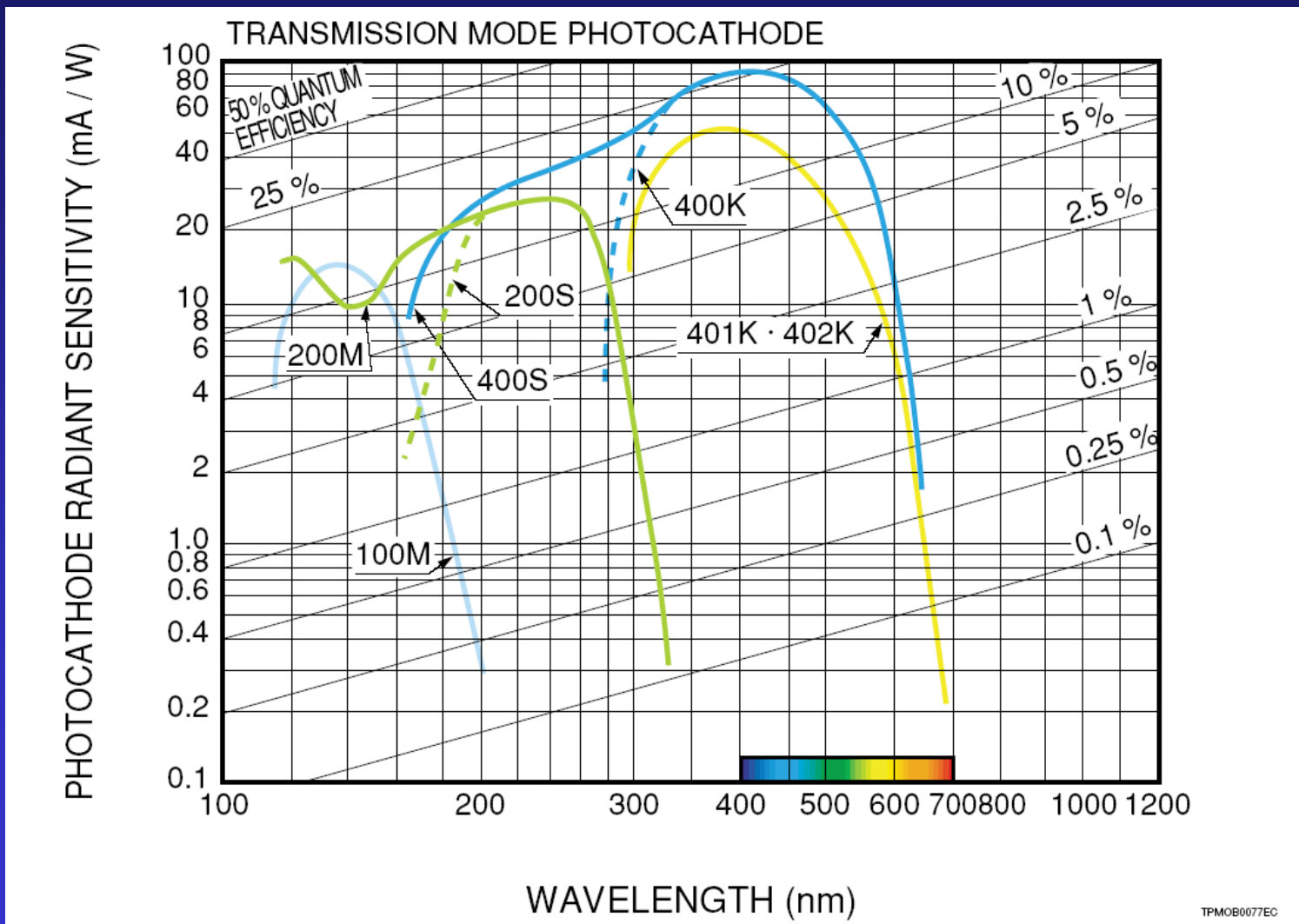

Spectral response

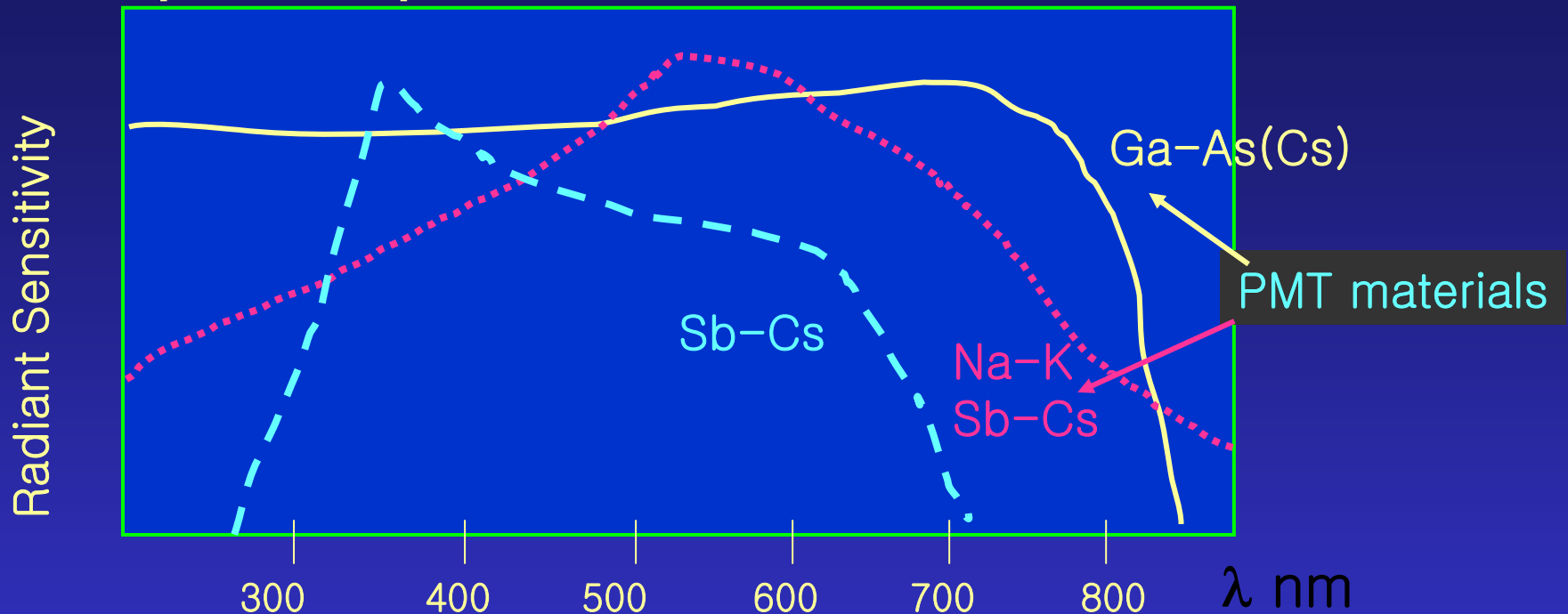

Cooling 을 하면 **spectral response** 가 달라진다 (**dark signal** 줄어듬)
 (Uv-visible 영역에서는 증가되고, IR 영역에서는 큰 변화 없다.)

- IR sensitive PMT – Cooling 요함.
- PMT dark signal (빛 새는 것, 주위 온도 높아서, 전류가 흘러서)

Bandpass Filter : A filter that transmits a continuous range (band) of wavelengths but reflects or absorbs wavelengths above and below this band. Bandpass filters are specified by the full width at half maximum (FWHM) of their transmission peak: wideband (>60 nm FWHM), medium band (20–60 nm FWHM), and narrowband (<20 nm FWHM). A typical narrowband transmission curve is shown below.

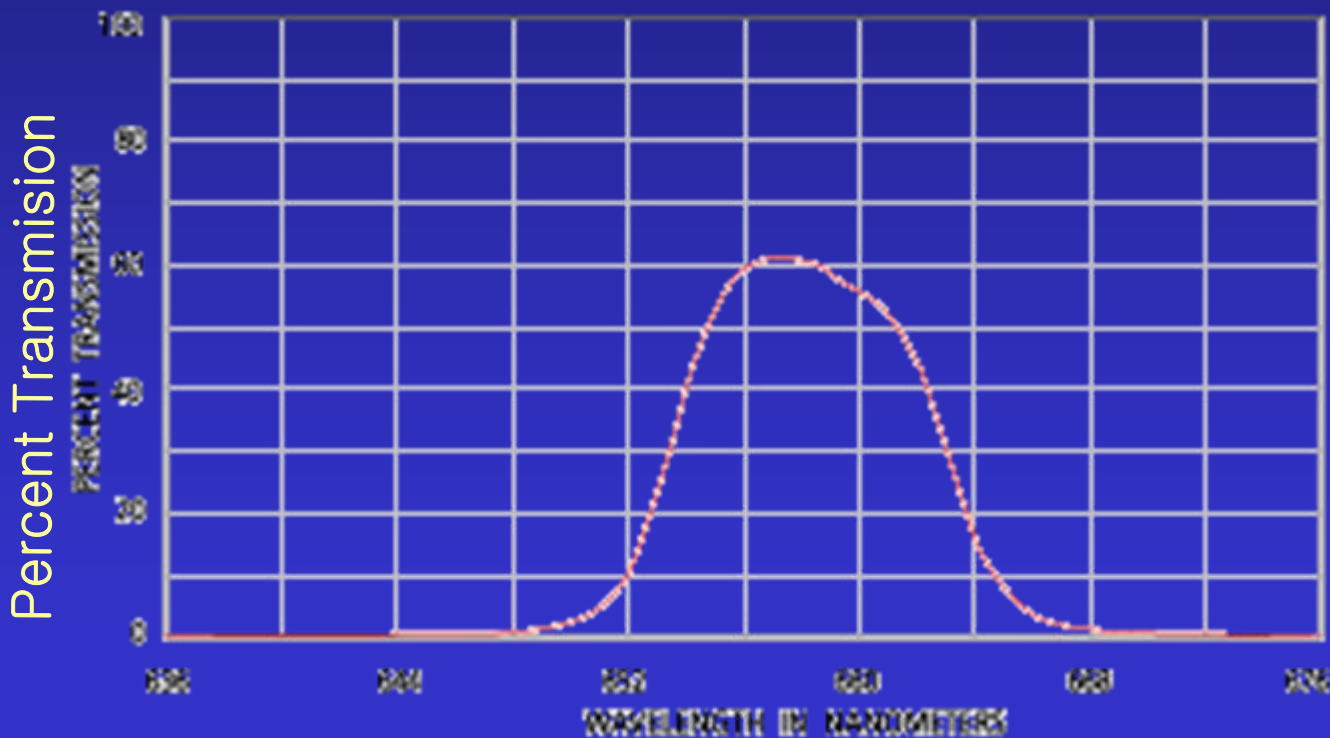

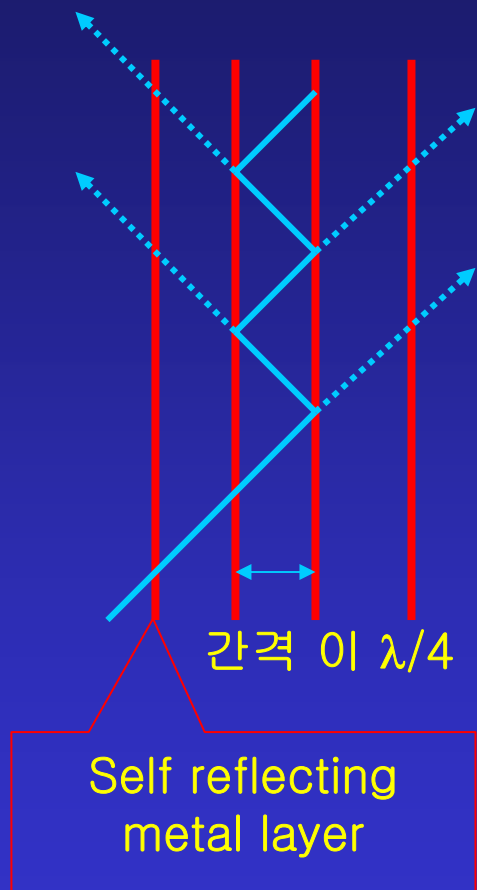

$$2n_e t \cos \theta = m\lambda$$

n_e : spacer refractive index

t : spacer thickness

θ : internal angle of incidence

m : 특정 파장의 배수 (자연수)

금속면이 광원 방향으로 향하게 !!

Antireflection Coatings (AR) At a simple interface between two dielectric materials, the amplitude of reflected light is a function of the ratio of the refractive index of the two materials, the polarization of the incident light, and the angle of incidence.

For light normally incident on an air/glass interface with the glass having a refractive index of 1.5, the intensity of the reflected light will be 4% of the incident light. For an optical system containing ten such surfaces, the transmitted beam will lose 1/3 of its intensity from reflection losses alone.

Surface reflection losses on an optical element can be reduced significantly by adding an antireflection (AR) coating. There are several types of antireflection coatings, the broadband single-layer coatings, broadband multilayer dielectric coatings, and V-coatings (narrowband multilayer dielectric coatings).

- Single-layer coatings:** Magnesium fluoride (MgF_2) is commonly used for single-layer coatings because of its almost ideal refractive index (1.38 at 550 nm) and high durability. At normal incidence, reflections are reduced to less than 2% per surface. A typical reflectance curve is shown below.

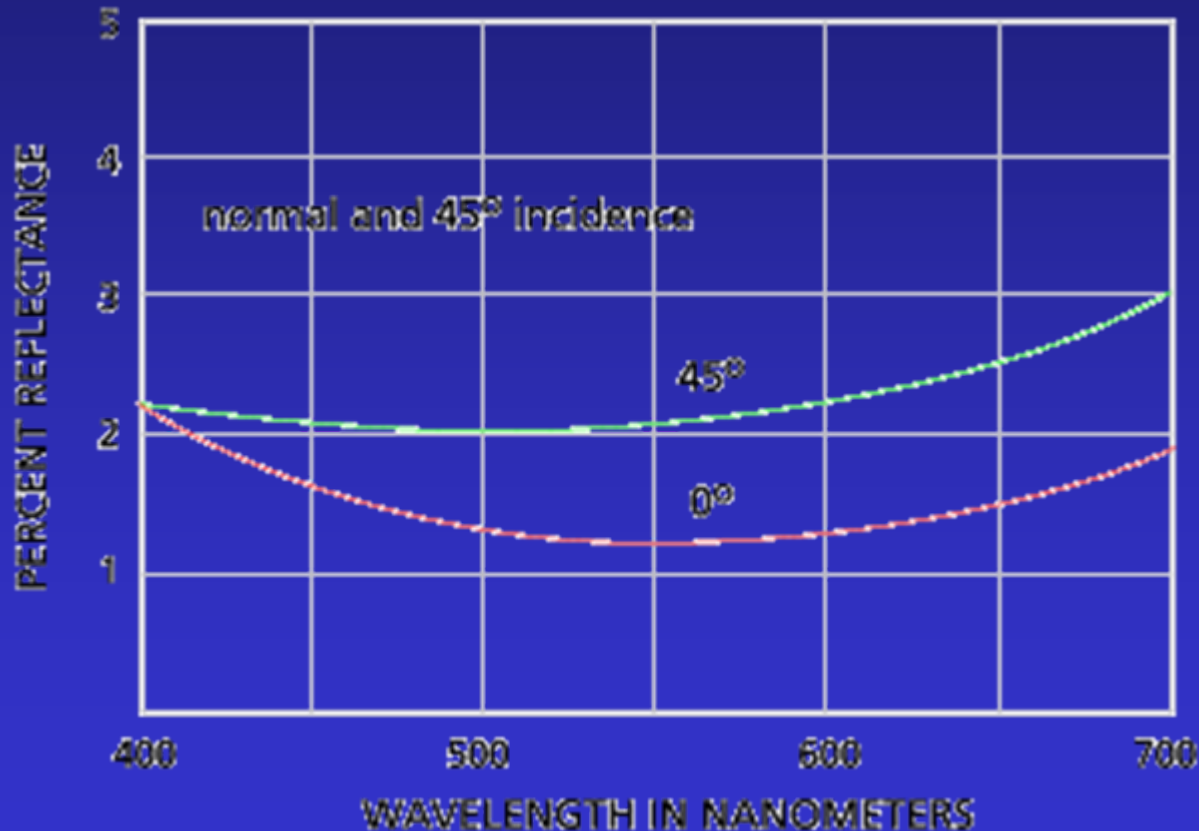

Photochemical Technique: Fluorescence Spectroscopy

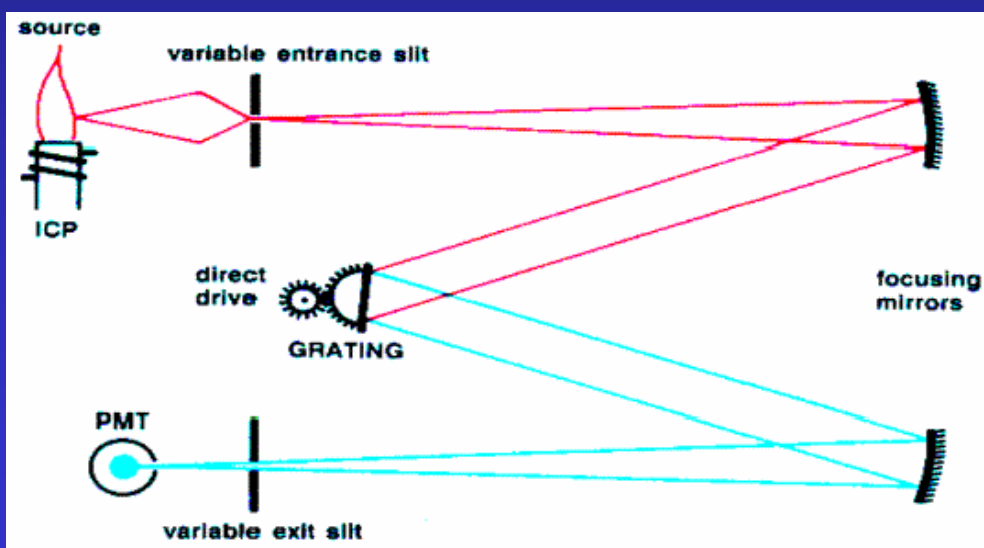

Photochemical Technique: Fluorescence Spectroscopy

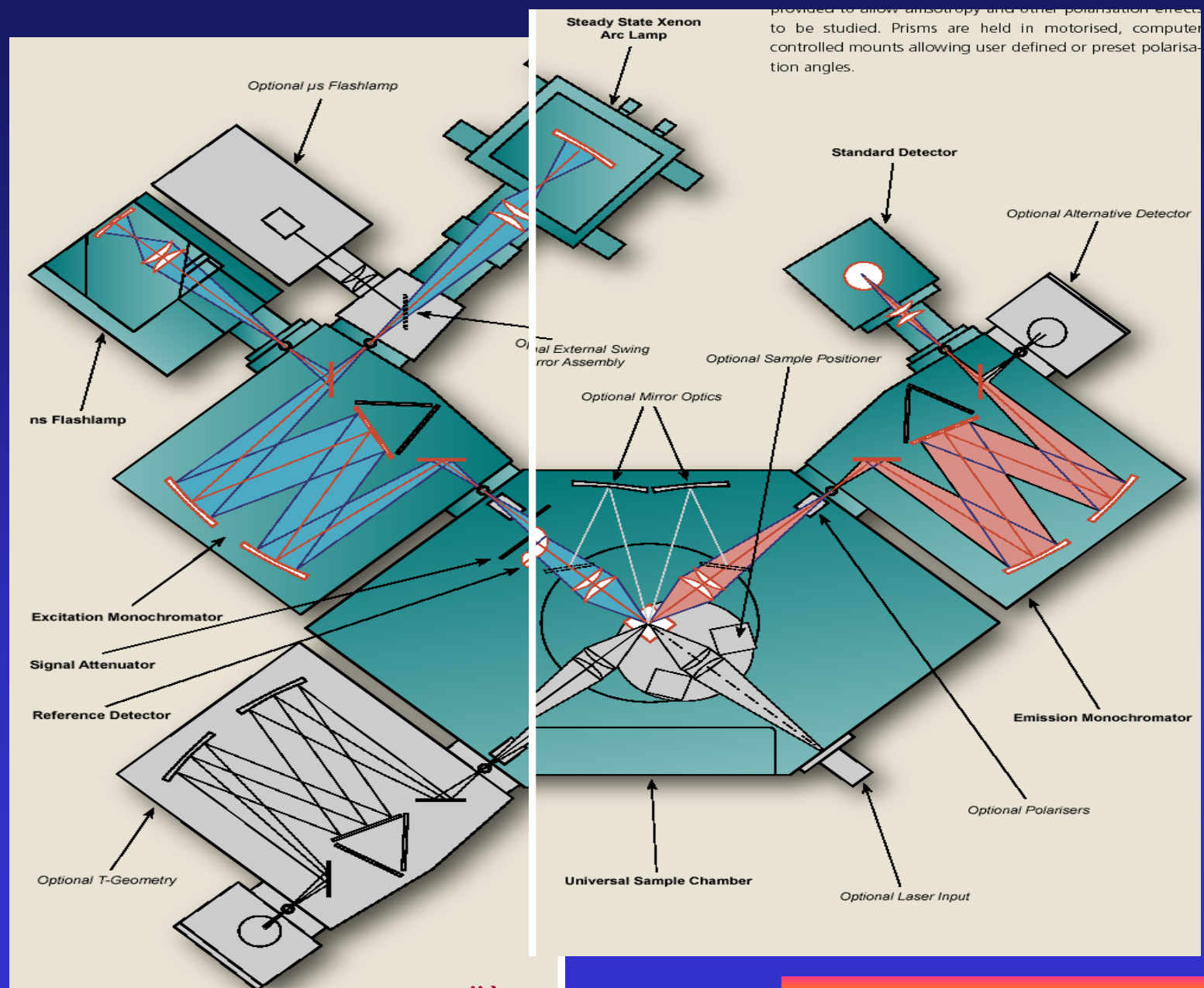

provided to allow anisotropy and other polarisation effects to be studied. Prisms are held in motorised, computer controlled mounts allowing user defined or preset polarisation angles.

Photochemical Technique: Fluorescence Spectroscopy

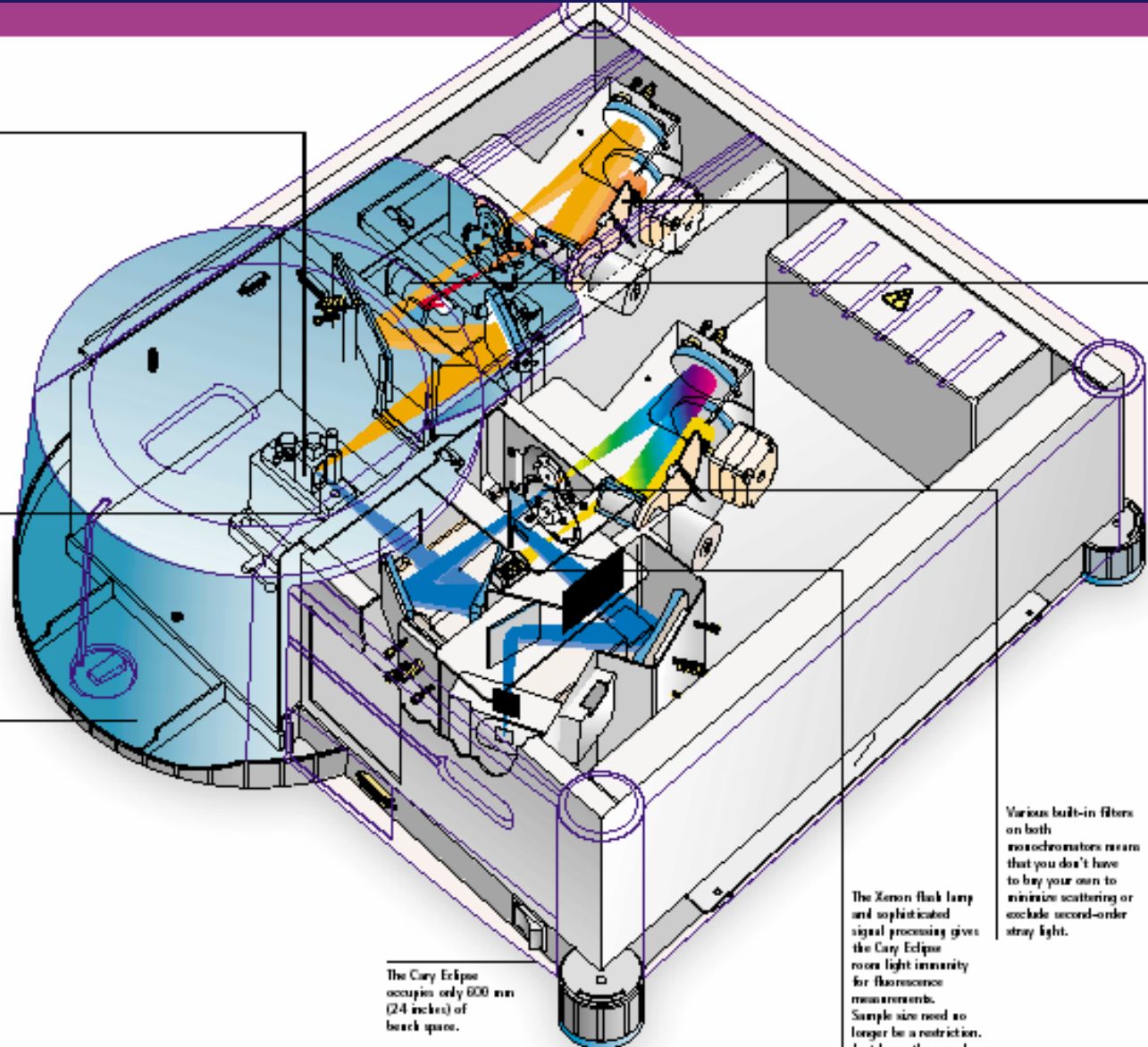

Excellent sensitivity is a result of using an intense Xenon flash lamp, coupled with optimized grating blaze angles and coatings which ensure sensitivity across the whole wavelength range. Photoactive samples are not exposed to continuous light as the Xenon flash lamp flashes only to acquire a data point.

Less than 0.5 ml is needed for a measurement in a standard cuvette. The horizontal beam profile ensures excellent sensitivity even with such low volumes.

The large sample compartment makes it easy to install and remove accessories. You have plenty of room to fit your own research apparatus. We can even provide a baseplate for you to build upon.

The Schwarzschild collection optics capture a large portion of the light from the powerful Xenon Flash lamp and direct it through the sample. This results in excellent sensitivity and low signal noise.

The Cary Eclipse occupies only 600 mm (24 inches) of bench space.

Scan fast—the whole wavelength range is less than 3 seconds.

Red-sensitive Photomultiplier tube detectors extend sensitivity up to 900 nm without sacrificing UV performance.

Various built-in filters on both monochromators means that you don't have to buy your own to minimize scattering or exclude second-order stray light.

The Xenon flash lamp and sophisticated signal processing gives the Cary Eclipse room light immunity for fluorescence measurements. Sample size need no longer be a restriction. Just leave the sample compartment open whilst collecting data!

- **Emission Spectrum**

Excitation wavelength 고정

Emission scan

- **Excitation Spectrum**

Emission wavelength 고정

Excitation scan

-

Photochemical Technique: Fluorescence Spectroscopy

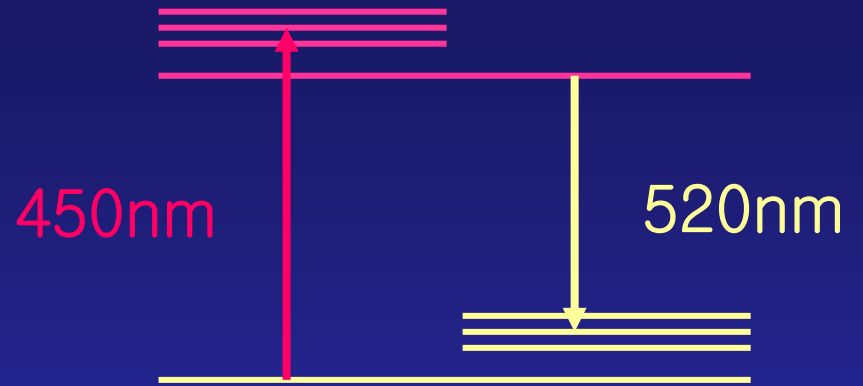
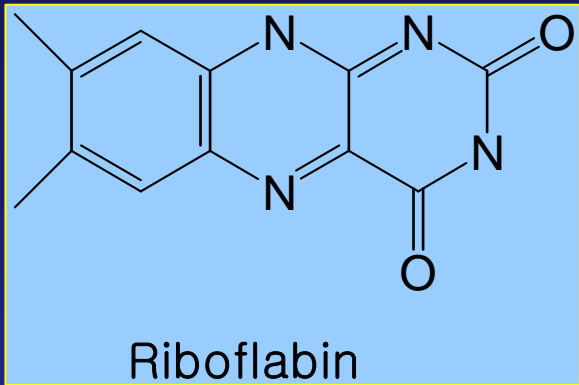

Perfect한 기계라면

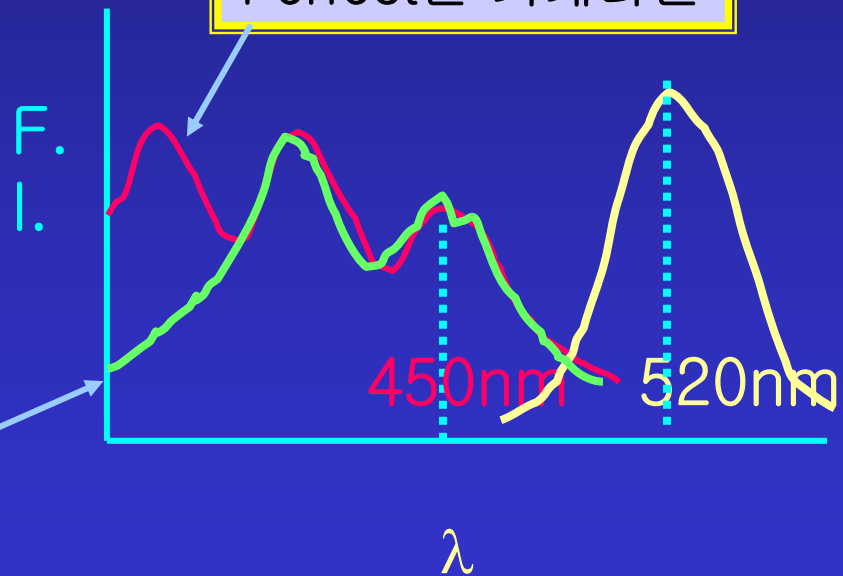
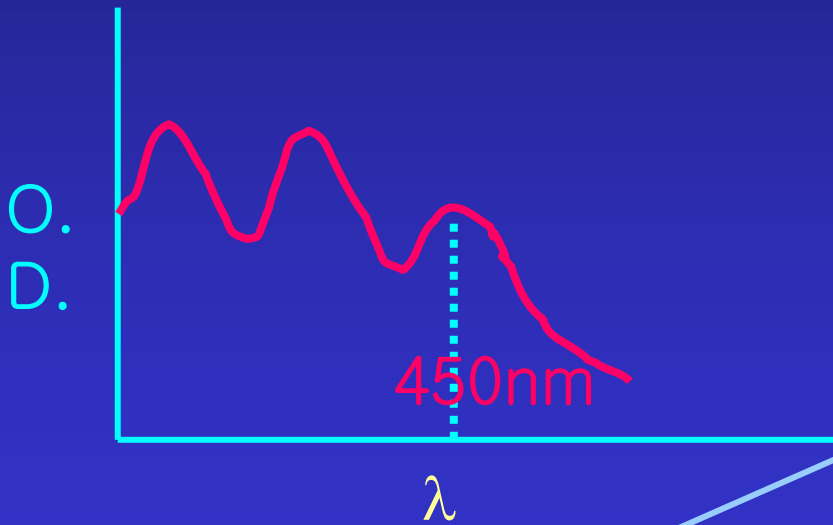

Correction 필요

- Excitation spectra obtnd at 520nm

$$I_F = I_0(1 - 10e^{-OD})\Phi_F$$
$$\cong I_0 \times OD \times \Phi_F$$

(용액이 5% 이내로 충분히 희석된 경우에 아래식 성립)

- **Factors affecting I_F**
 1. I_0
 2. OD
 3. Φ_F
 4. PMT spectral response
 5. Monochromator spectral response
 6. Other optics spectral response

- Spectral response corrections

Lamp : Hg-Xe Arc

Fluctuation이 심하다.

I_0 : 시간에 따라 변하면 문제 발생

ex) 200nm에서 600nm로 scan시 I_0 같아야 한다.

5시간 후에도 I_0 가 같아야 한다.

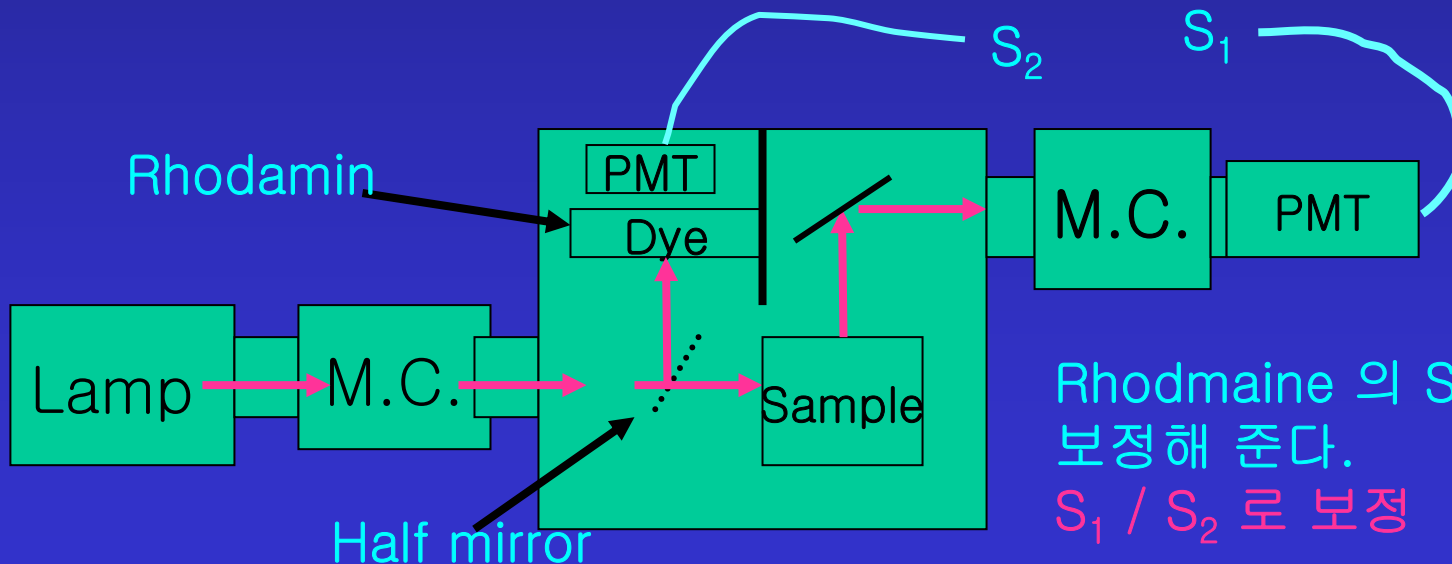

- 문제: 다음과 같이 농도가 높을 때 형광이 줄어드는 이유는?

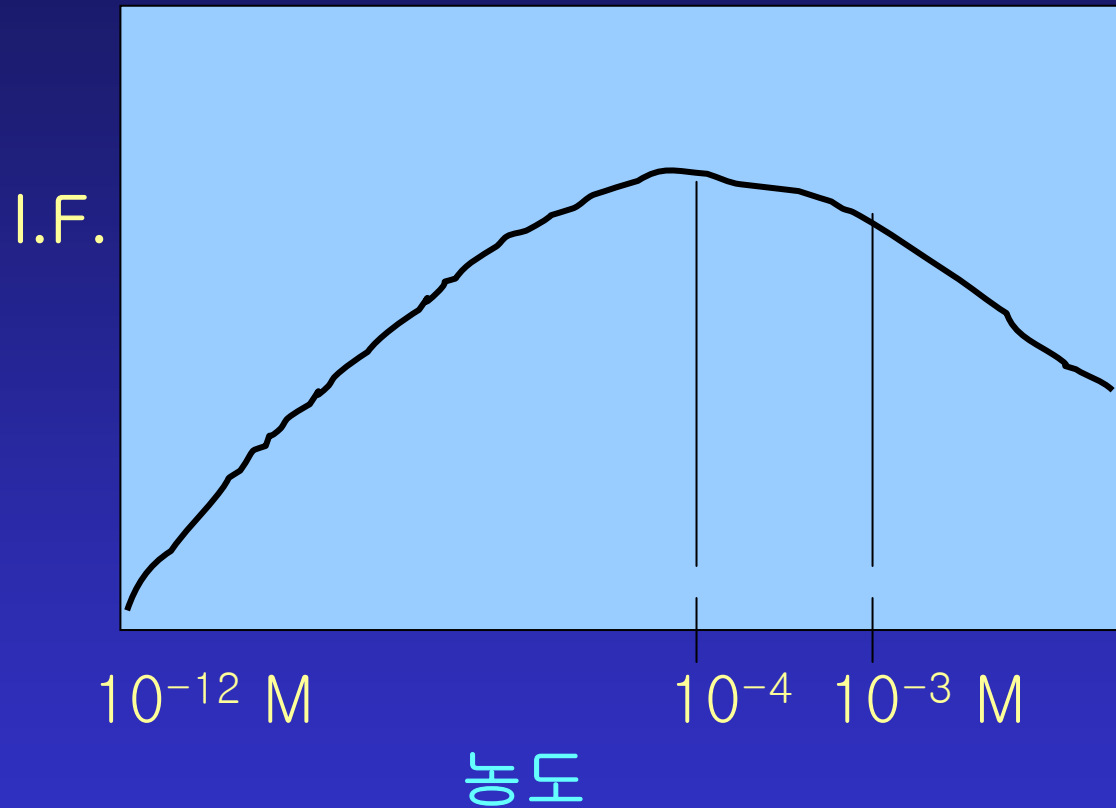

- 문제: 다음과 같이 농도가 높을 때 형광이 줄어드는 이유는?

• **Beers Law:**

$$\log \frac{P_0}{P} = A = abc$$

- **a** : 흡광계수 (extinction coefficient)
- **b**: path length **c**: concentration

예)

$$A = 0.8, \quad \frac{P_0}{P} = 10^{0.8} \quad T = \frac{P}{P_0} = 0.16 \quad 16\% \text{ 통과}$$

$$A = 2.0, \quad \frac{P_0}{P} = 10^2 \quad T = \frac{P}{P_0} = 0.01 \quad 1\% \text{ 통과}$$

- 표면에서 (front surface)에서 빛이 모두 흡수된다.

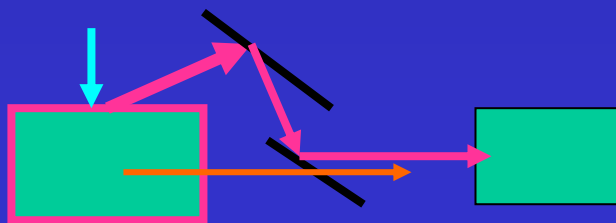

front surface에서 나오는 빛을 모아서 **detect**한다.

- Action Spectra

- 형광을 내는 물질 또는 생물 소자의 파장에 따른 특성

- stentor 가 싫어하는 정도

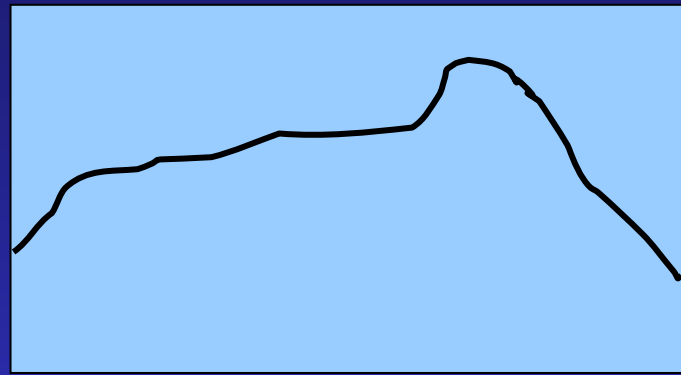
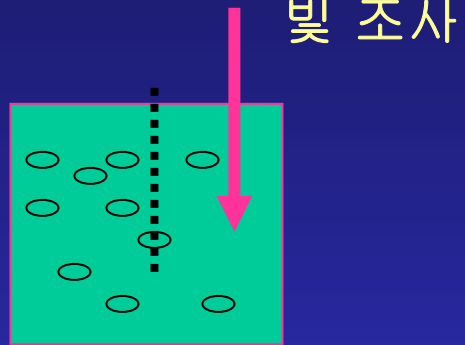

파장

- Light Amplification by Stimulated Emission of Radiation

Stimulated Emission

(일반적인 emission은 spontaneous emission이다)

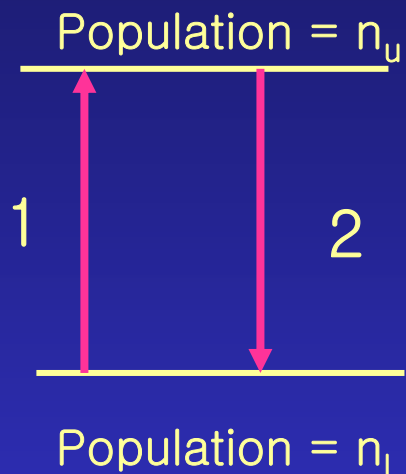

$$\text{Rate of absorption} = n_l B_{lu} \rho$$

n_l : # of molecules in the lower state

B_{lu} : Einstein Coefficient

ρ : a given radiation density

$$\text{Rate of emission} = n_u B_{ul} \rho$$

n_u : # of molecules in the upper state

$$B_{ul} = \frac{64\pi^4 \nu^3}{3hc^3} \langle \psi_u | \mu | \psi_l \rangle^2$$

Normally $n_l > n_u$

- If 2 process is suppressed,
- In other words: rate of absorption > rate of emission

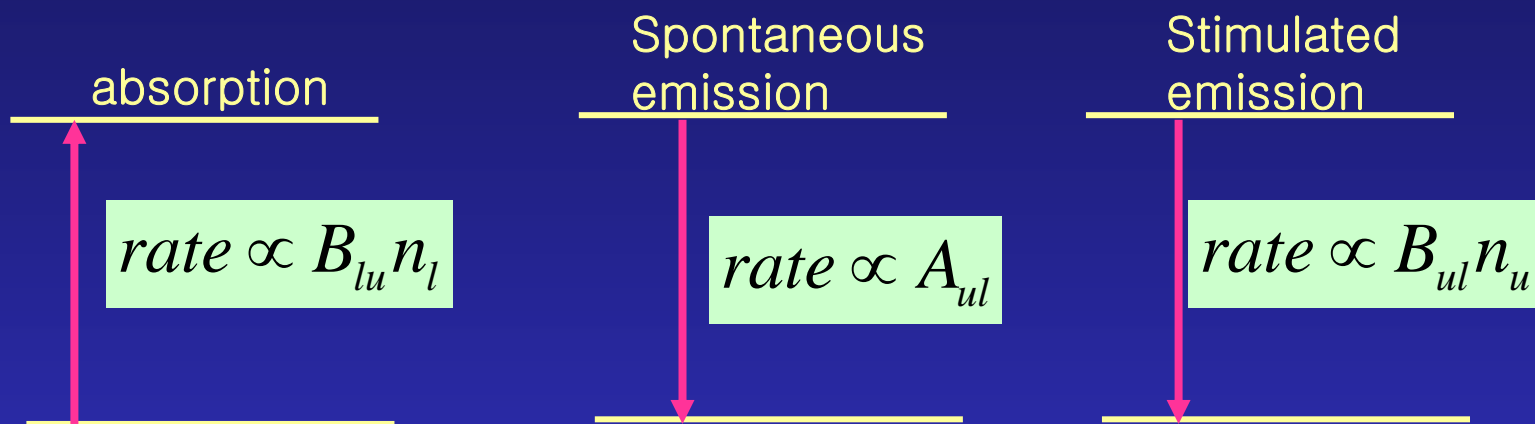

Then $n_l < n_u$

- Three Types of Optical Transitions

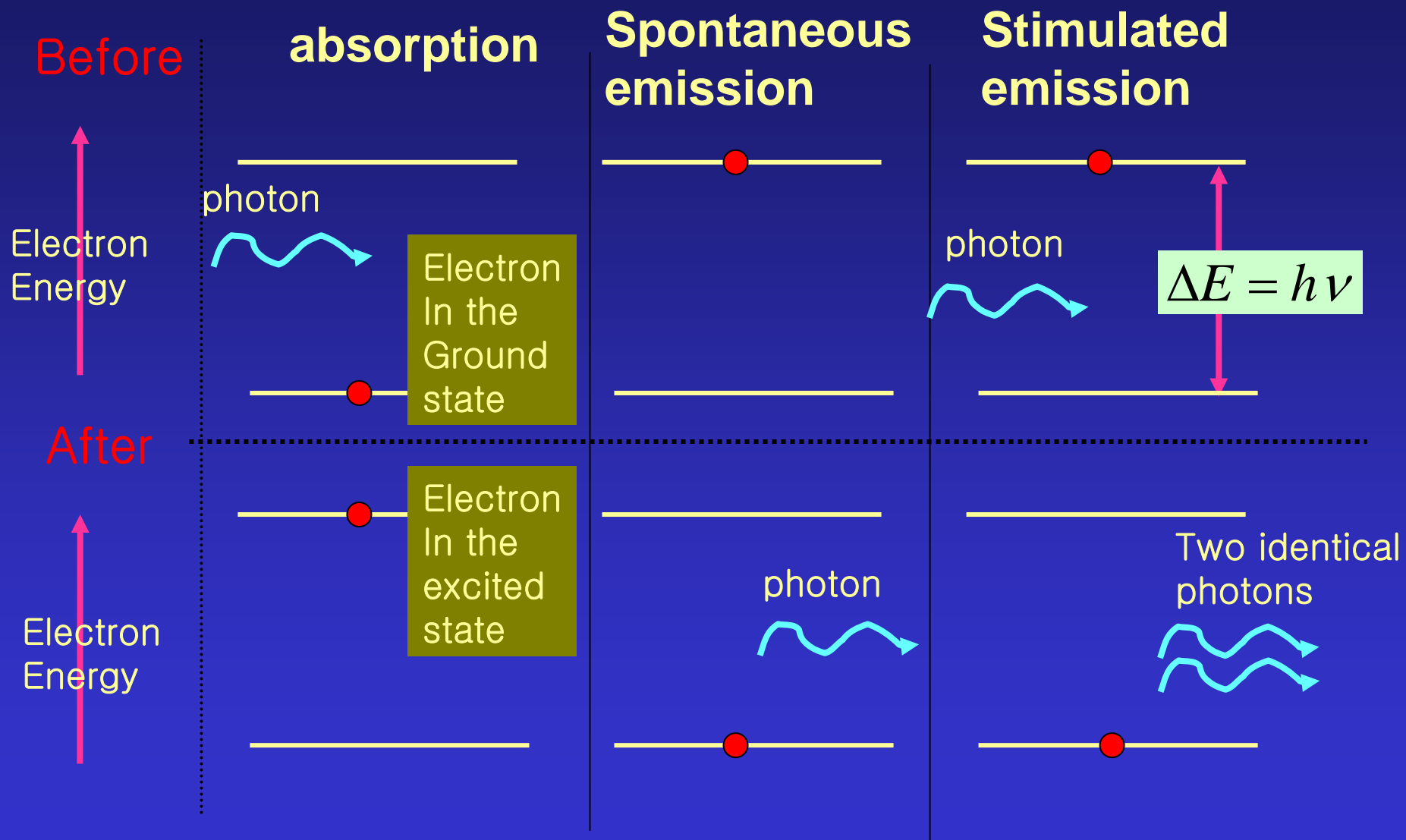

- If $n_u > n_l$, there is possibility of average overall amplification for an array of photons passing through a volume of these particles.

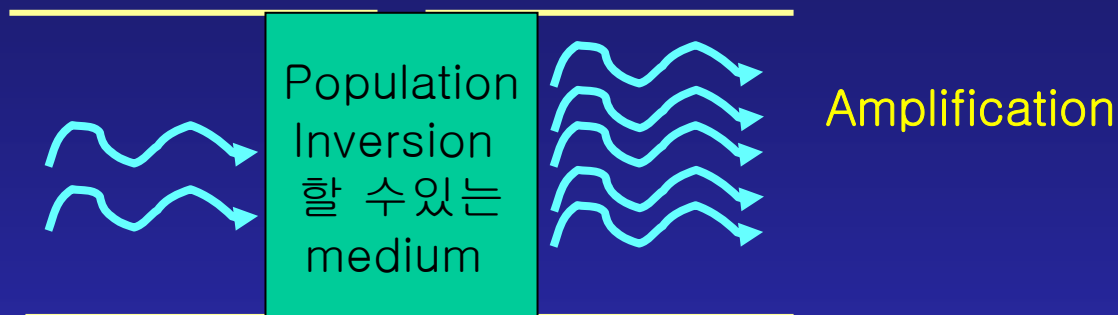

- Spontaneous emission depletes n_u at a rate proportional to A_{ul} , which is coefficient of spontaneous emission.

$$A_{ul} = \frac{8\pi h \nu^3}{c^3}$$

- **Schematic Diagram of a Laser**

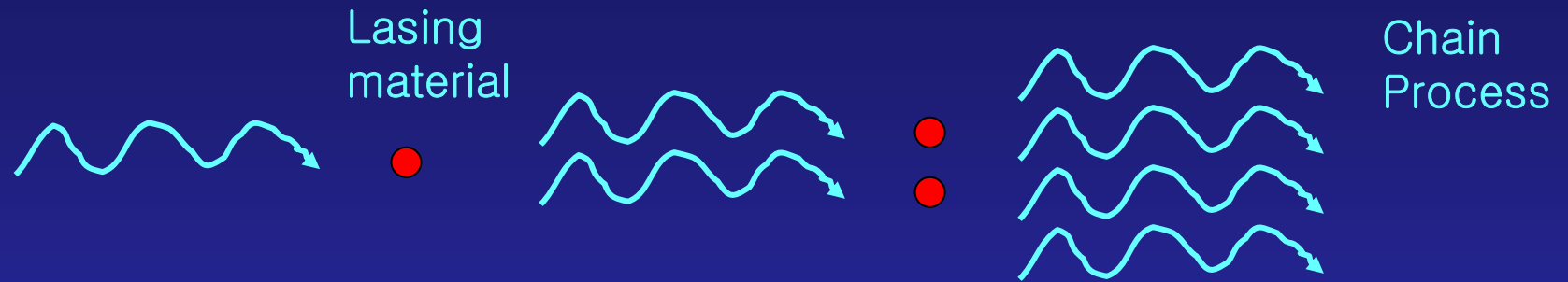

- 한 순간에 **population inversion**을 없애고 빛을 내 보낸다. (약 1 μsec)

- **Schematic Diagram of a Laser**

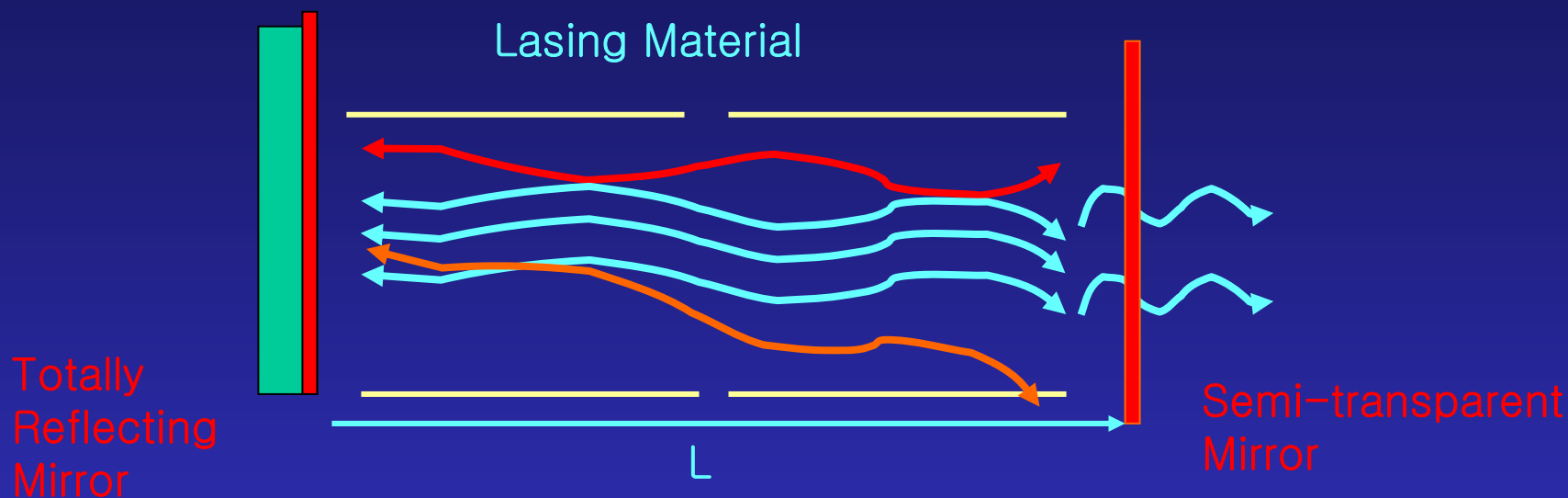

- **Two parallel mirrors are separated by**

$$L = n\left(\frac{1}{2} \lambda\right) \text{ 이 때 } E_u - E_l = hc / \lambda \text{ 를 만족}$$

- **Light reflected from a mirror will be in phase with the incident wave (constructive interference)**

- **Characteristics**

All lasers produce **intense beams** of light that are **monochromatic, coherent, and highly collimated**. The wavelength (color) of the laser light is extremely **pure** (monochromatic) when compared to other sources of light, and all of the photons (energy) that make up the laser beam have a **fixed phase relationship** (coherence) with one another. This causes the light to form a beam with a **very low rate of expansion** (highly collimated) that can travel over great distances, or can be focused to a very small spot with a brightness that can approximate that of the sun. Because of these properties, lasers are used in a wide variety of applications in all walks of life

Characteristics

1. Coherence

Phase가 다르면 **destructive interaction**에 의하여 소멸된다. **In-phase**만 남는다.

Phase 뿐만 아니라, **mirror**와 **mirror**사이가 **standing wave**가 되도록 조정되어 있다.

2. Highly monochromatic

한가지 **frequency** 만 증폭되게 된다.

3. Accurate parallelism

두개 거울에 수직이 되지 않는 빛은 **cavity**에서 튀어나간다.
Beam size 작고, **E**가 크다 (**short pulse laser**, 10^9 W/cm^2).

4. Brightness

$10^{-3} \text{ W} \sim 10^{12} \text{ W}$ **power**를 갖는다.

Photochemical Technique: Laser 종류

Attribute	HeNe		Ion		Diode		HeCd		DPSS	
	λ (nm)	P (mW)	λ (nm)	P (mW)	λ (nm)	P (mW)	λ (nm)	P (mW)	λ (nm)	P (mW)
Wavelength/Power	543 594 612 633	3 5 7 40	457 488 514 568 647 752	50 150 150 20 100 20	405 408 440 635 640 660 685 780 785 830	1 24 1 3 12 22 15 7 35 40	325 442	55 130	430 442 457 473 532 1064	10 10 400 15 3000 5000
Beam Quality	Excellent		Very Good		Good		Very Good		Very Good	
Cooling	Convection		Forced Air		Convection		Forced Air		Convection/ Forced Air	
Efficiency	Good		Poor		Excellent		Good		Very Good	
Battery Operation	Yes		No		Yes		No		Yes	

Spectral Region	Available Wavelengths (nm)	Output Power (mW)
Multiline Visible	457 – 647	25 – 400
Tunable Visible	454 – 647	4 – 195
Violet	405, 430, 440, 442, 457	1 – 130
Blue	457, 473, 488	4 – 400
Green	514, 532, 543	0.2 – 3000
Yellow	568, 594	0.35 – 20
Orange	612	0.5 – 2
Red	633, 650, 685, 647	0.5 – 100
Near Infrared	752, 830, 1523	0.8 – 20

Laser와 population inversion 방법

- Two Level

$$B_{lu} \approx B_{ul} \quad \rho: \text{same}$$

$$n_u \approx n_e$$

- 따라서 population inversion 이 어렵다.

-> Three level system으로

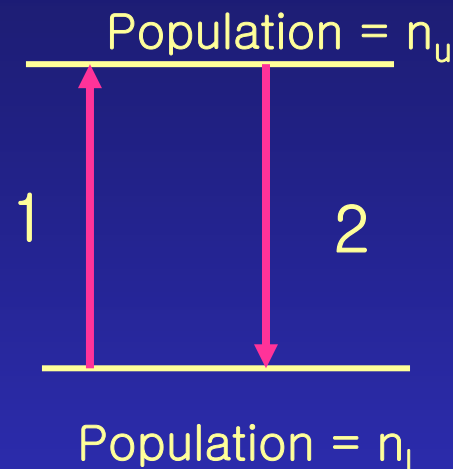

Laser와 population inversion 방법

- **Three Level**

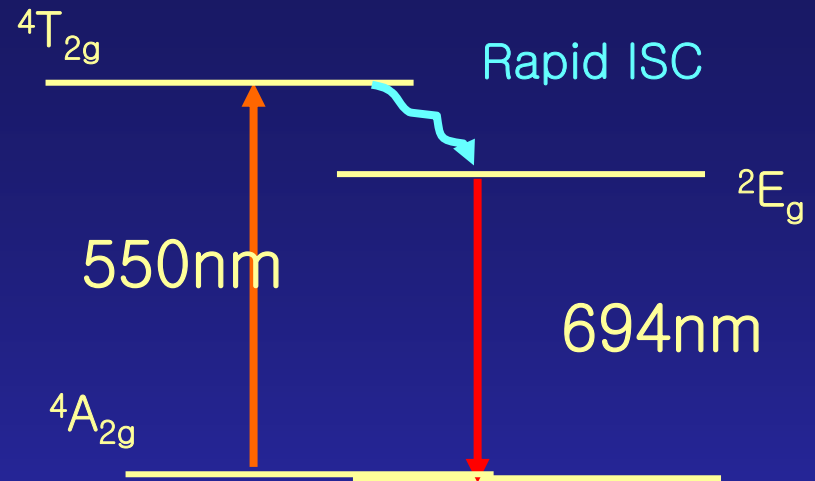

Energy levels for Cr³⁺ ions in Ruby Laser.

- **Rapid intersystem crossing populates the $2E_g$ state.**

- **The characteristic red laser emission occurs from the $2E_g$ state.**
- **문제점: inefficient more than 50% of Cr ion 이 $2E_g$ state로 여기되어야만 lasing.**

Laser와 population inversion 방법

- 4 Level system

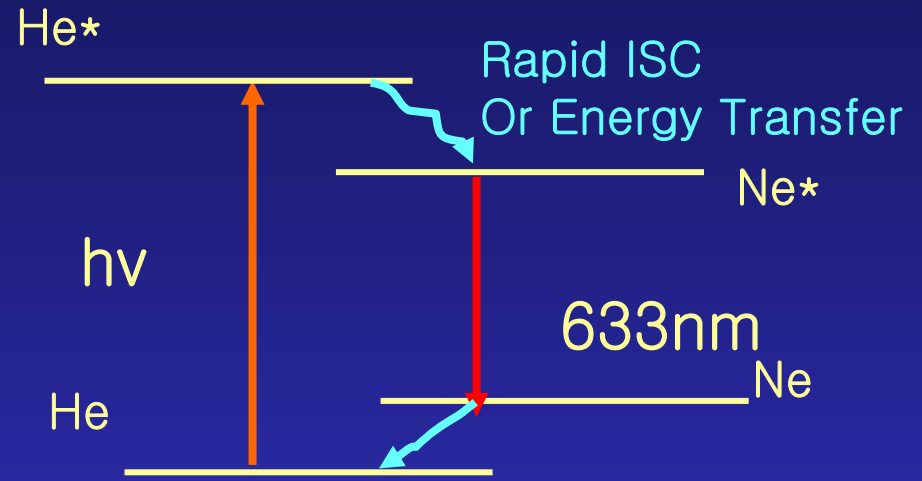

Energy levels for He-Ne Laser.

- 이런 경우 계속해서 **population inversion**이 가능하므로 **continuous operation**이 가능하다.

Laser와 population inversion 방법

Lasing at Simple semiconductor junctions

- No voltage applied
- Missing e^- , mobile holes extra mobile e^- ,

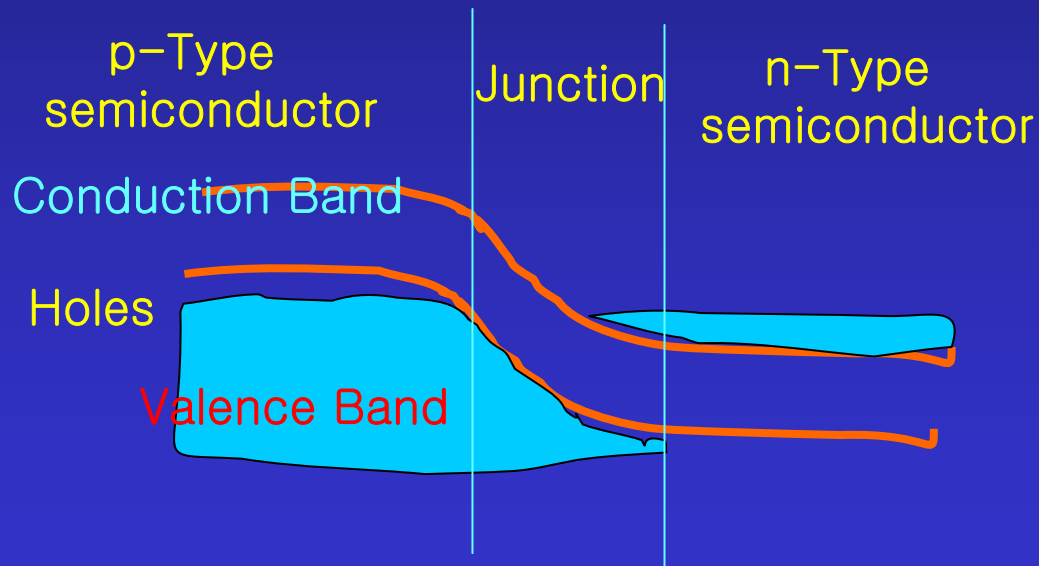

Laser와 polpulation inversion 방법

Lasing at Simple semiconductor junctions

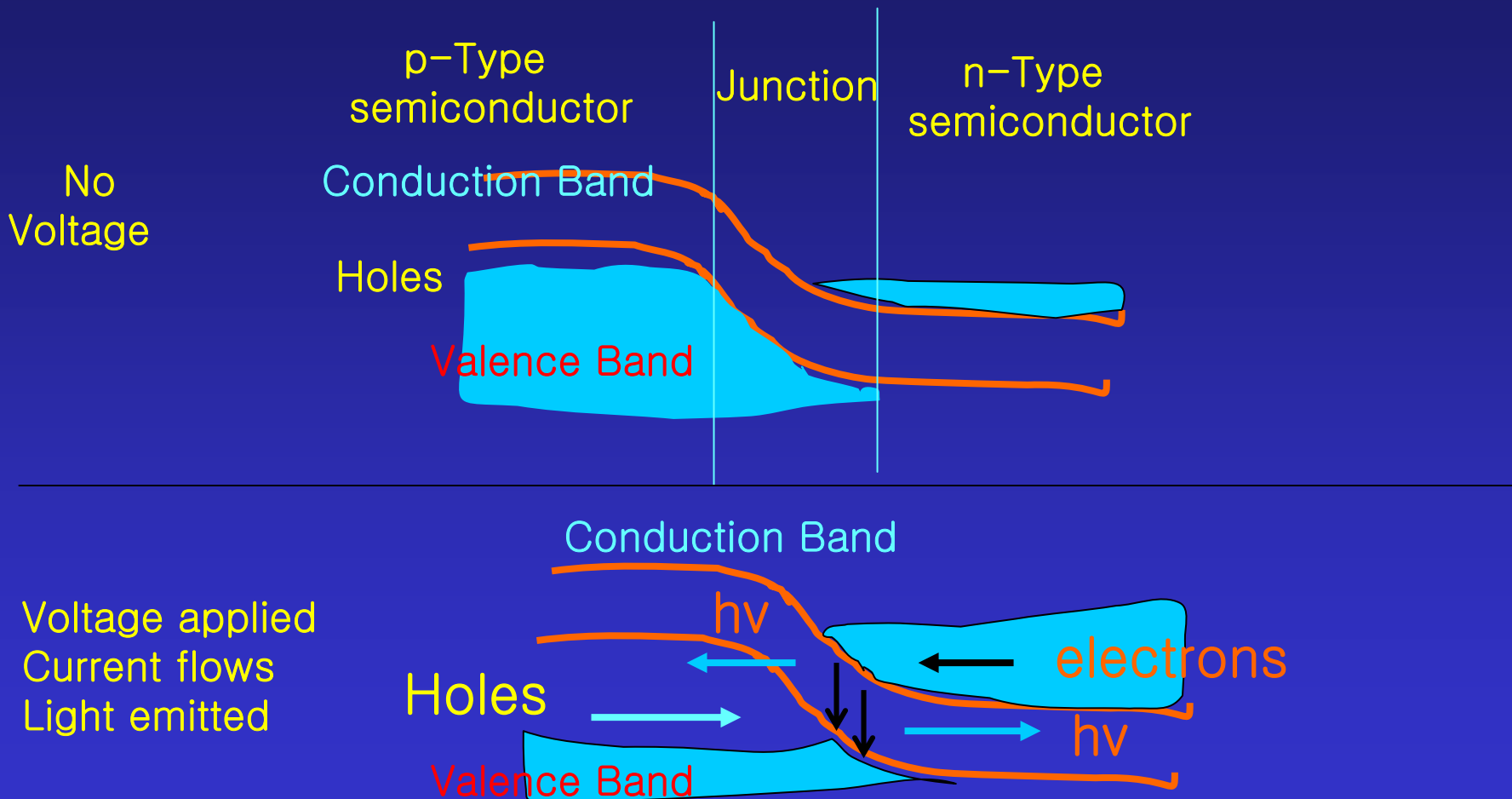

- When current flows across the junction, holes and electrons recombine: electrons relaxed from the conduction band to valence band. The relaxation energy is released as photons.
- 여기에 p-n junction이 잘 doping 되고, 높은 전류를 걸면, population inversion of electrons and holes can be induced in the junction region. 이것을 optical cavity에 걸면 laser.

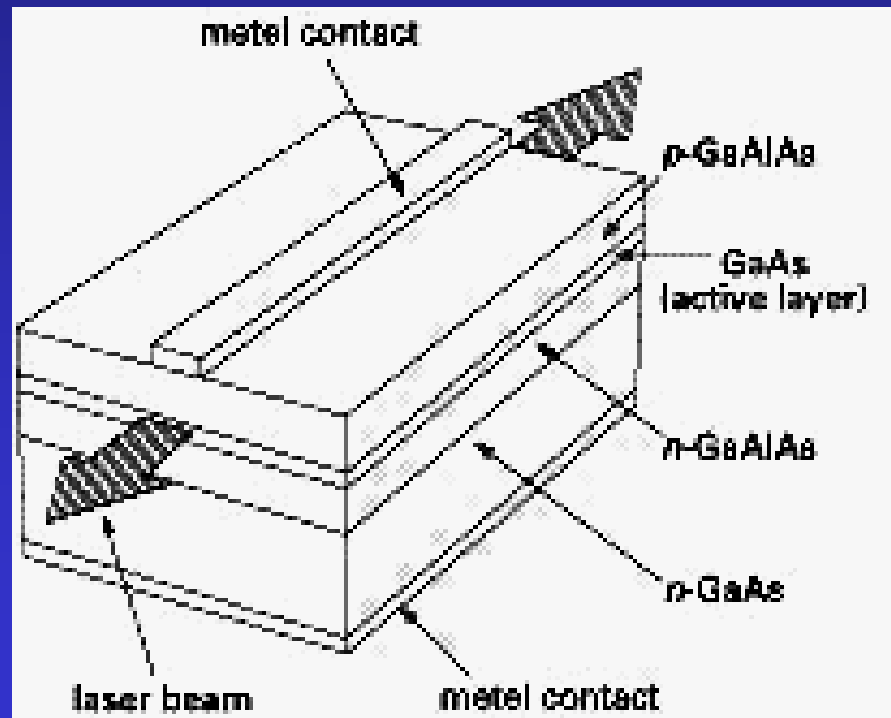

They can be tuned.

Wavelength of their light output can be varied.

(often over as much as 50 nm)

- Dye laser는 2 level system 같아 보이나 사실상 4 level system이다. 따라서 continuously operate 가능

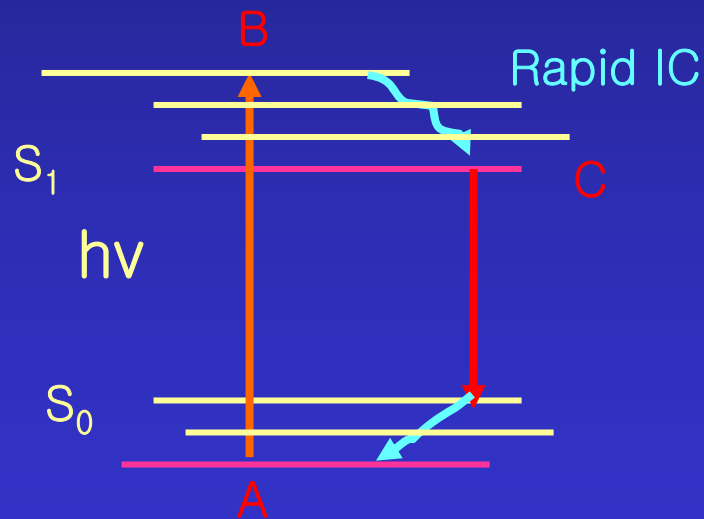
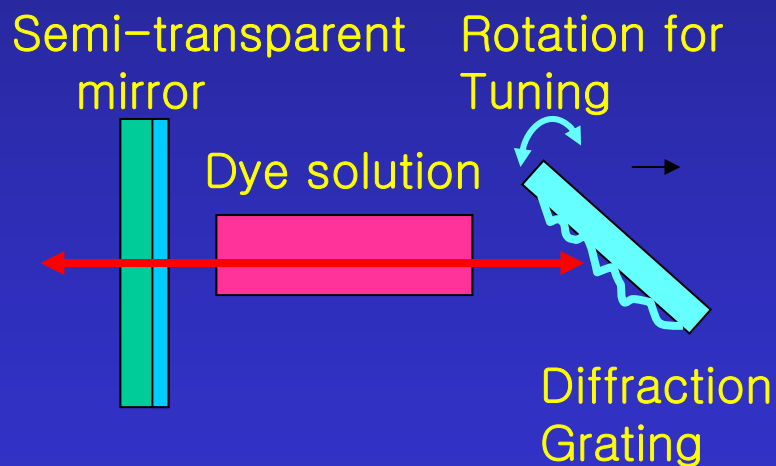

Energy levels for Dye Laser.

• Q-switching Technique

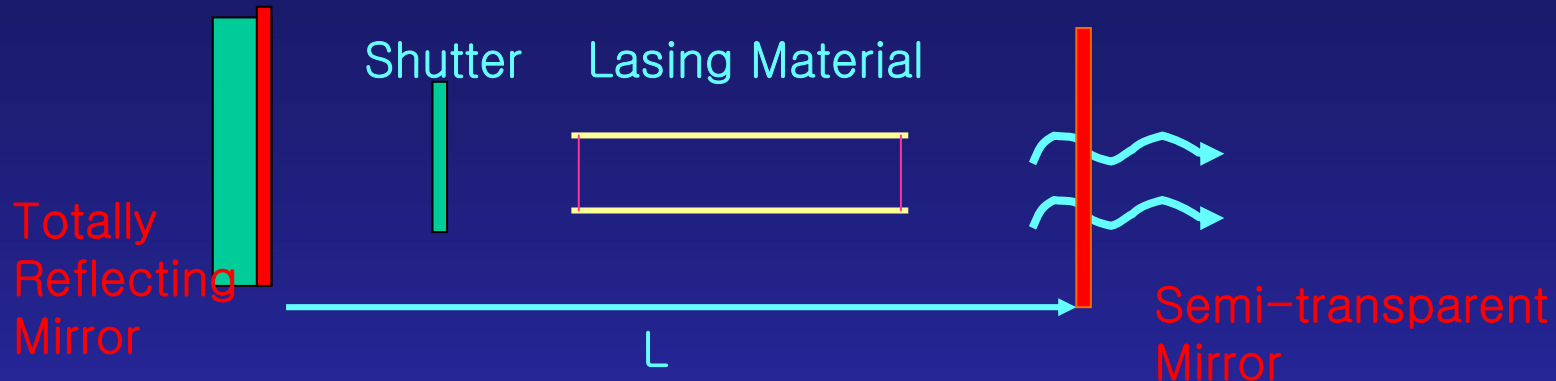

- **Simple laser**는 약 $1 \mu\text{sec}$ 정도의 **pulse** 를 갖는다. 이유는 **laser emission**이 **population inversion**이 달성되어야만 생기기 때문.
- **Shutter opens with extreme rapidity.**
- 처음에는 **shutter closed & radiative absorption** (이 경우 **amplification** 은 거의 없다.)
- **Shutter** 갑자기 열면 **amplification**이 갑자기 상승.
- 저장되었던 **energy**들이 **giant pulse**로 되어서 **release**.
- 1 J의 **ruby laser**가 Q-switch로 **10ns duration, peak power 100MW**의 **pulse** 발생

형광 lifetime 측정
Set-up의 하나.

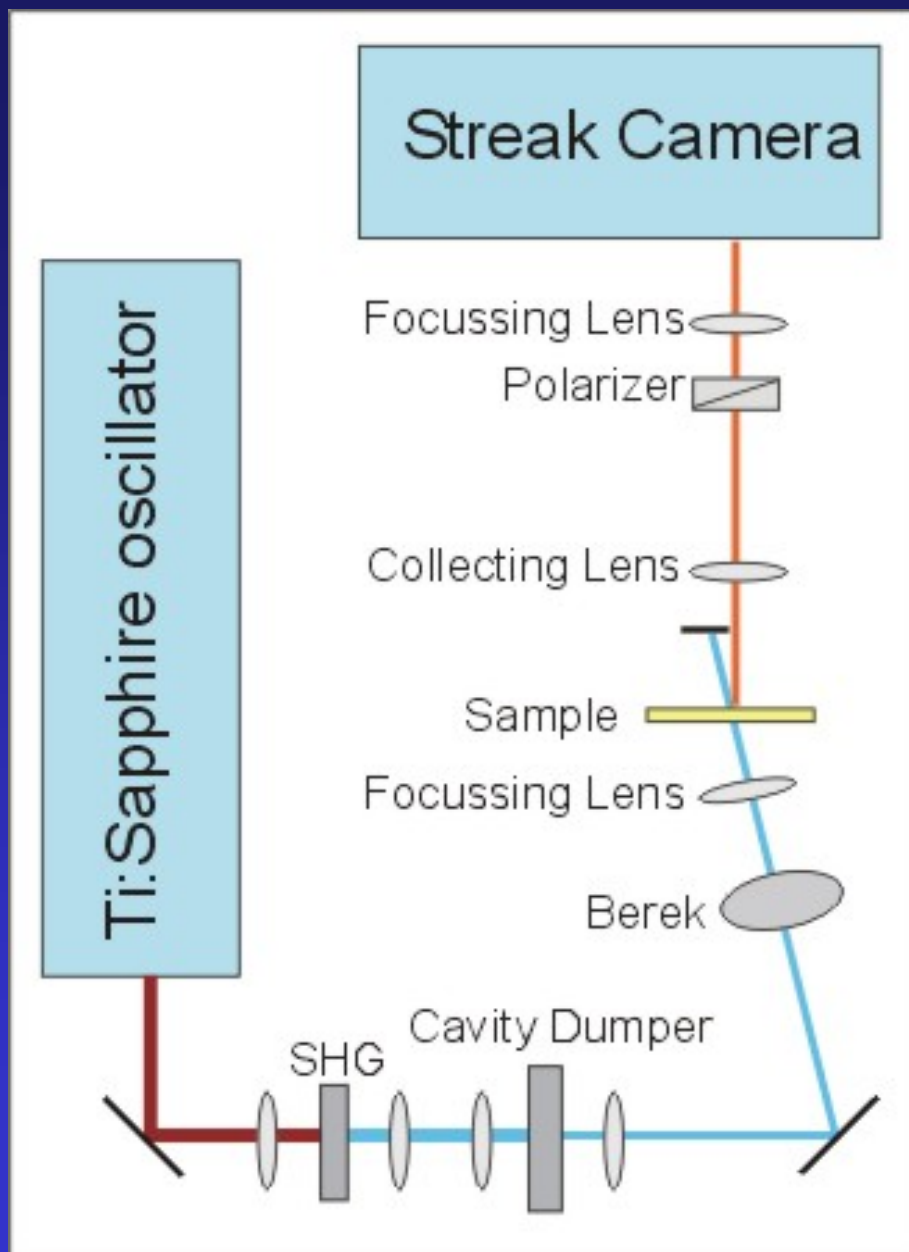

The experimental setup in figure 1 has - besides the streak camera itself - four main elements:

- **A BBO-crystal** that is used to frequency double (SHG) the light from the Ti:Sapphire oscillator.
- **A cavity dumper** that reduces the repetition rate from 82 MHz to 4 MHz. This ensures that there will not be an overlap in the fluorescence decay from two consecutive pulses in molecules with a long lifetime.
- **A polarizer** that is fixed to transmit vertical polarized light only since the sensitivity of the streak camera depends on the polarization.
- **A Berek polarization compensator** that is used to turn the polarization of the excitation light. It is thereby possible to detect fluorescence parallel, at magic angle (54.7°), and perpendicular relative to the excitation pulse without turning the polarizer in front of the streak camera. This is highly convenient in anisotropy measurements.

The Streak Camera - general facts

The streak camera used in the department uses a [Hamamatsu C 4742-95](#) camera. The streak camera enables detection of the fluorescence as a function of the spectral and the time evolution simultaneously. The fluorescence can be detected in two spectral windows with the width of 50 nm or 100 nm. There are six different time windows to choose from, varying in size from 100 ps up to 2 ns. The time resolution in the shortest window is 1 ps, when the system is well aligned.

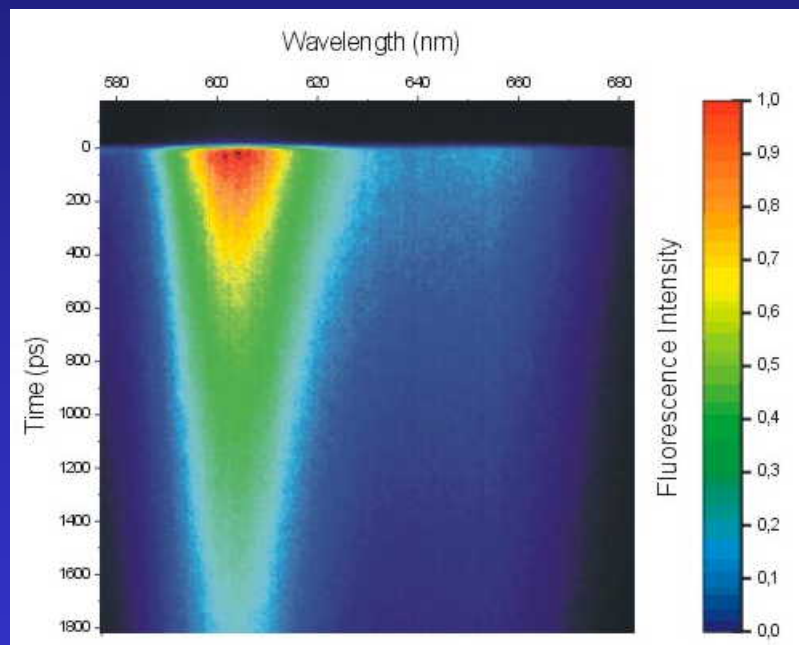

An example of a 3D image obtained with the streak camera. The streak camera measures the fluorescence intensity -illustrated with the colours, increases from black/blue towards red- as a function of both wavelength (horizontally) and time after excitation (vertically).

The principles of the streak camera

The Ti:sapphire oscillator excites the sample and it emits fluorescence.

The fluorescence from the sample is distributed in space by a grating giving a 3D picture of the incident light, which is projected on the slit. After passing through two lenses, the light hits a photocathode connected to a mesh plate that accelerates the generated electrons. A sweep circuit - synchronized to the laser pulses - deflects the electrons onto the multi channel plate (MCP) depending on the moment of their emission, thereby introducing the time resolution. Hence the photons emitted directly after excitation experience a higher voltage than the photons emitted at a later time. The signal is then transferred to a phosphor screen and detected by a CCD camera yielding a 3D picture.

The principles of the streak camera

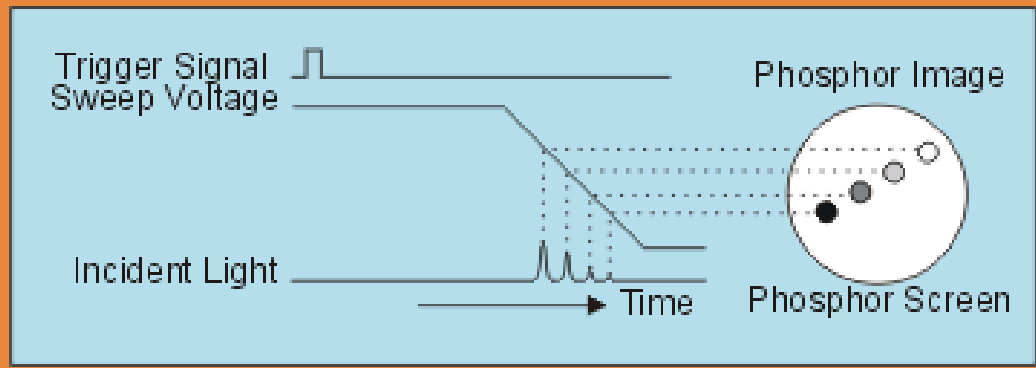
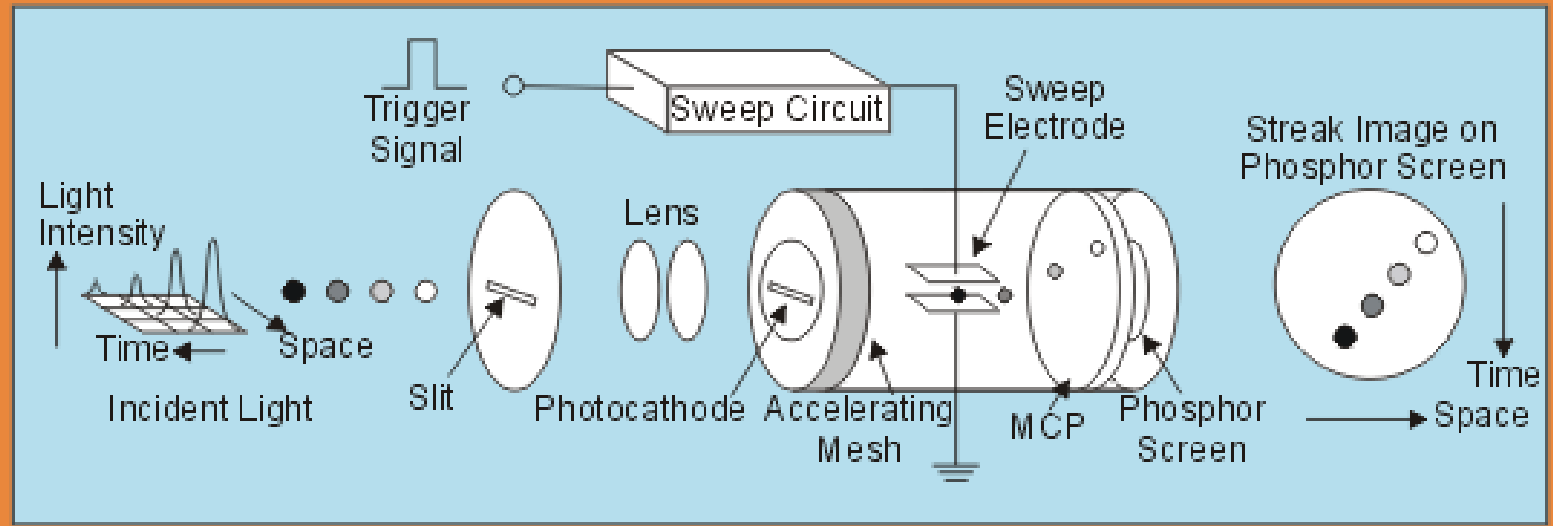

일반적인 **PMT**를 사용하거나 **PDA**를 이용하였을 경우 얻어지는 **spectrum**의 형태

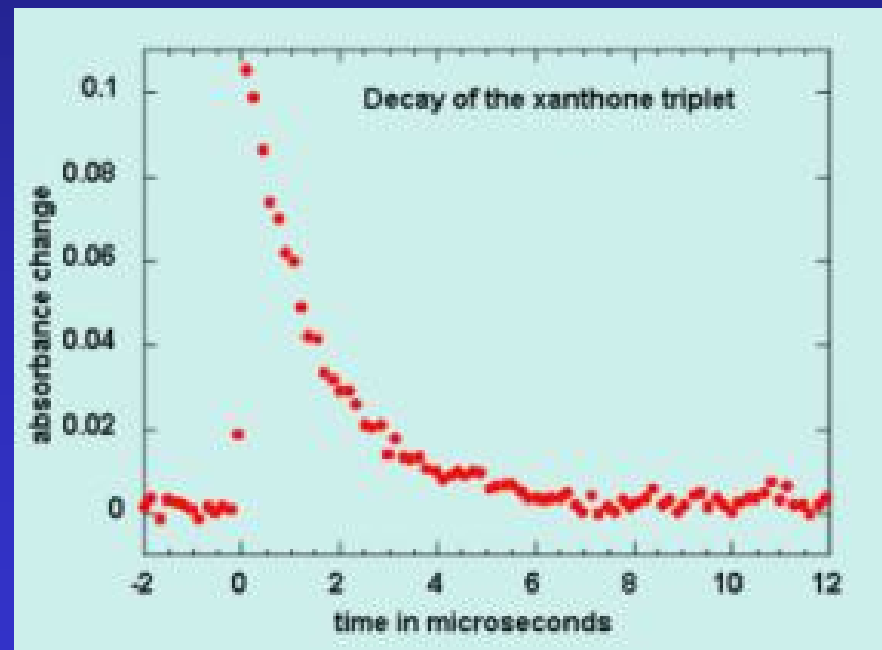
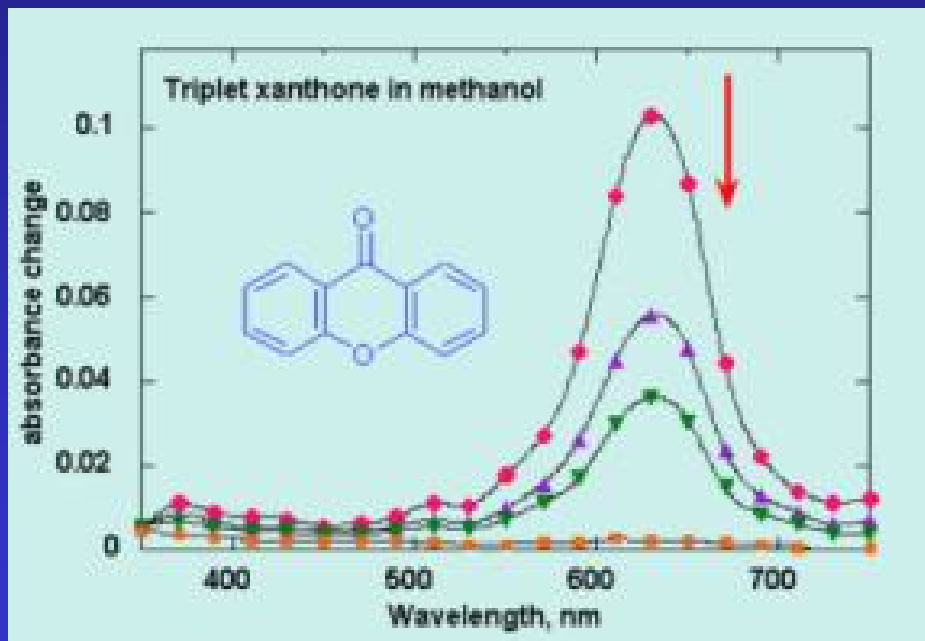

Photochemical Technique: Time Correlated Single Photon Counting

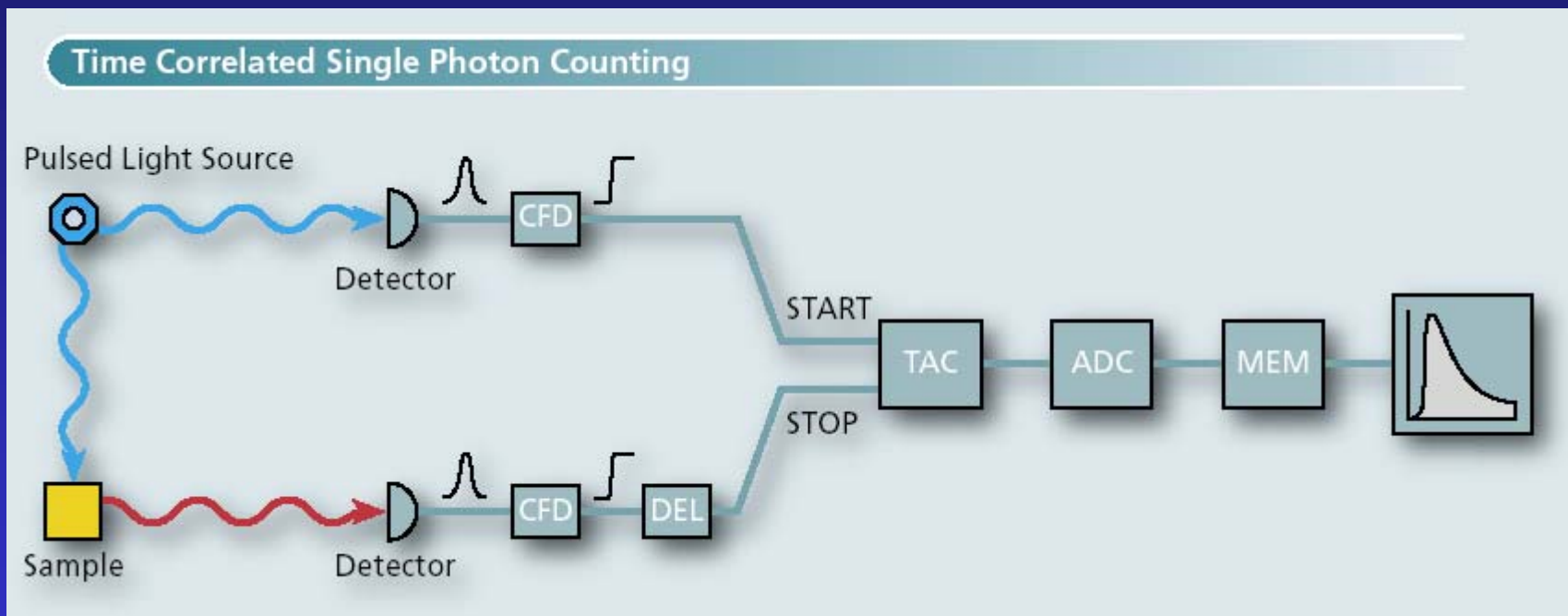

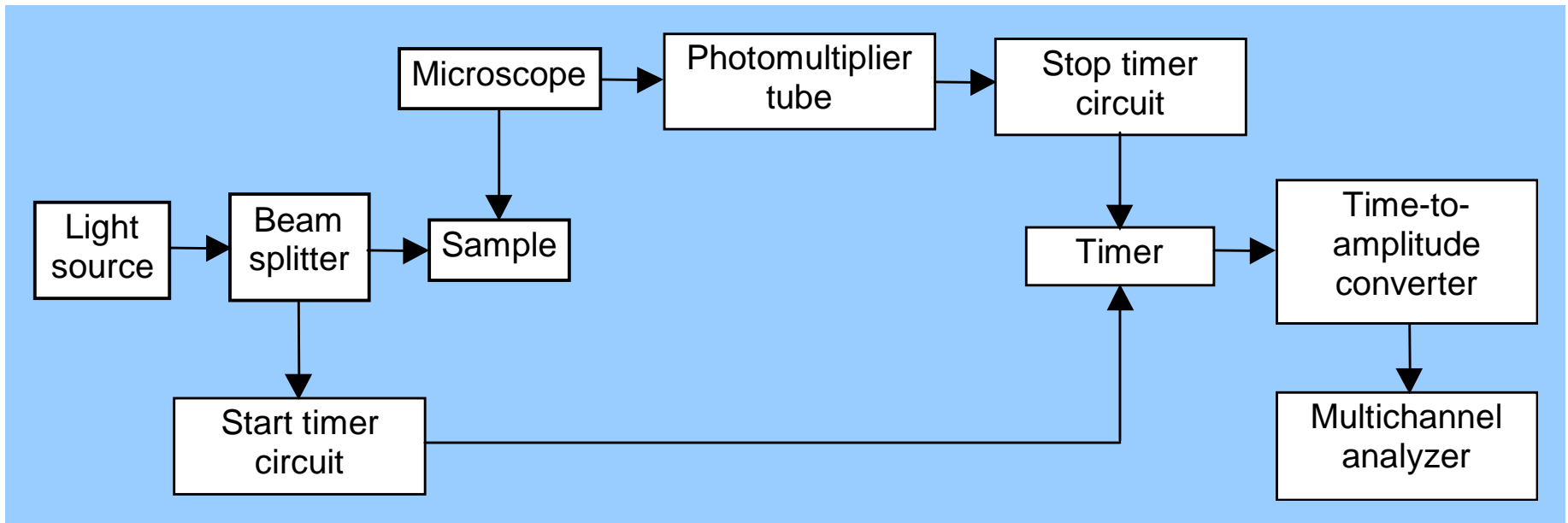

Time-correlated single photon counting system block diagram. When a light source provides an excitation pulse, some of the light is deflected to the start timer circuit while the rest illuminates the sample. A single fluorescent photon is detected by a photomultiplier tube, which generates a pulse that stops the timer. The time difference is then converted to an amplitude. The various amplitudes are recorded in the multichannel analyzer and a profile of different time intervals versus number of photons in that interval are displayed.

- **Time to amplitude converter (TAC)**

Start signal이 **TAC on** 시키면 **voltage** 증가하기 시작한다.

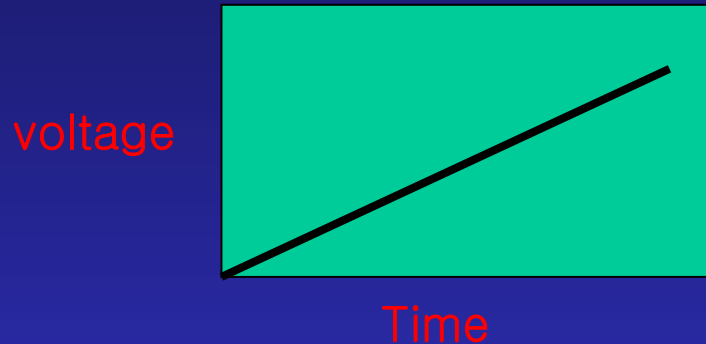

Stop signal 이 도착하면 **TAC off** 이 때 **voltage**를 읽으면 이것이 시간으로 전환된다.

Short lifetime의 경우 **short pulse laser**를 사용한다. (예: **argon-ion laser**) – **single photon**만 측정하기 때문에 **laser**의 **power**는 중요하지 않다.

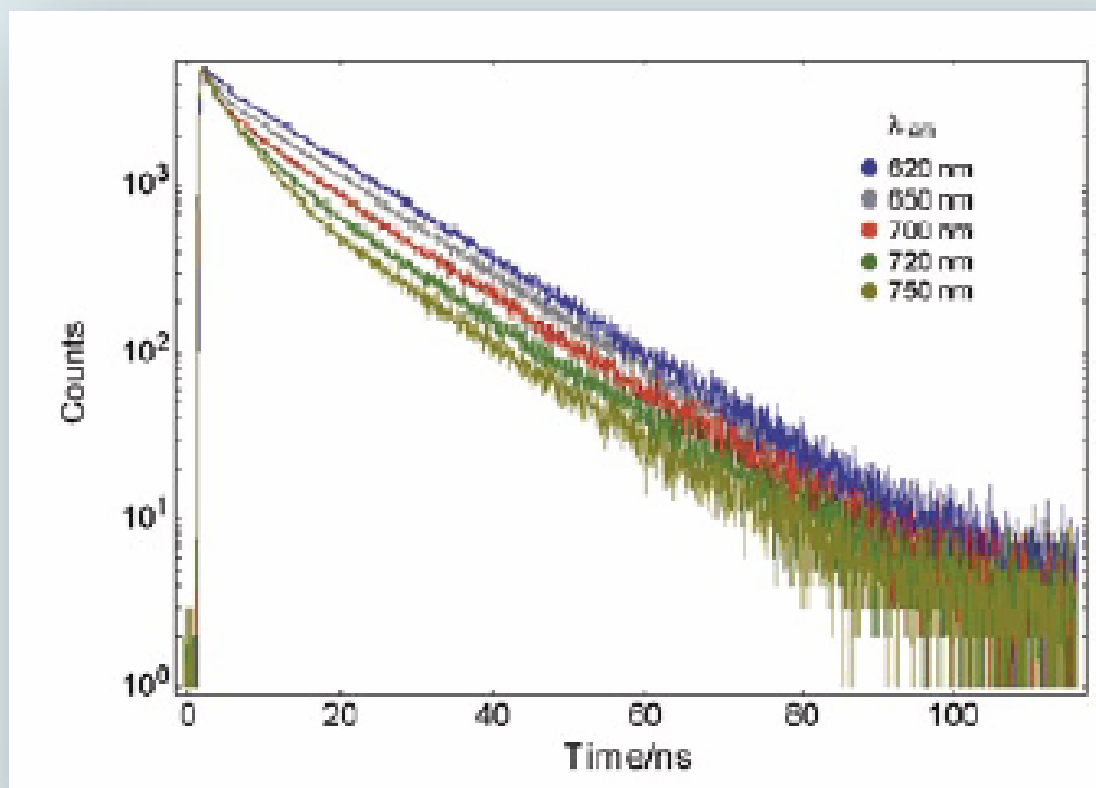

Sample: Hematoporphyrin IX in water at pH 7.2.

Measurement Conditions: Picosecond Diode Laser, rep.rate = 1MHz,
MCP-PMT Detector, $\lambda_{ex} = 400\text{nm}$

Emission changes from single lifetime of 14.8ns at 620nm to a triple exponential decay of 0.8ns, 4.4ns and 14.8ns at 750nm

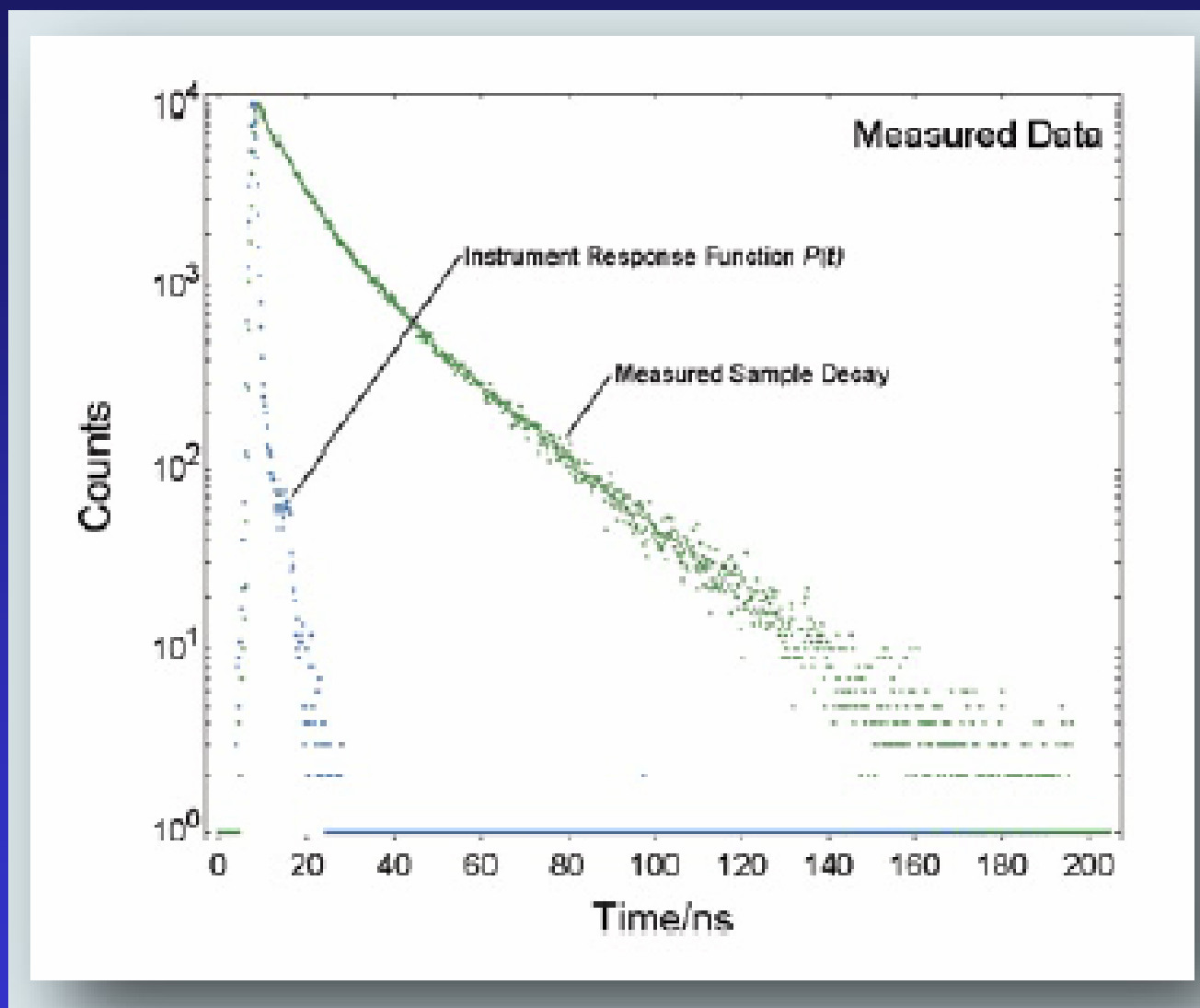

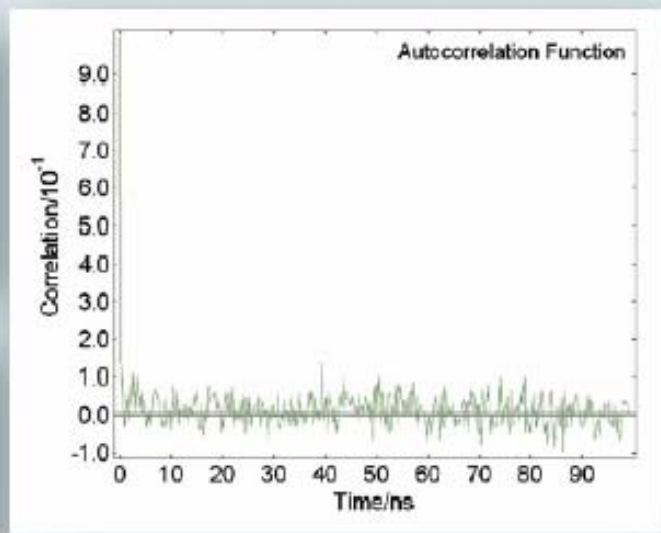
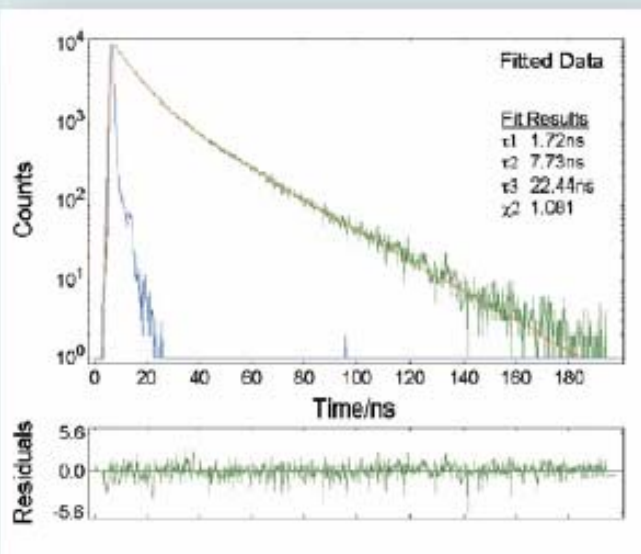

The correct fit is found for three exponential decays with a χ^2 value of 1.081, a clean autocorrelation function, more than 99% of all data points falling within 3 standard deviations and a Durban Watson parameter of 1.676.

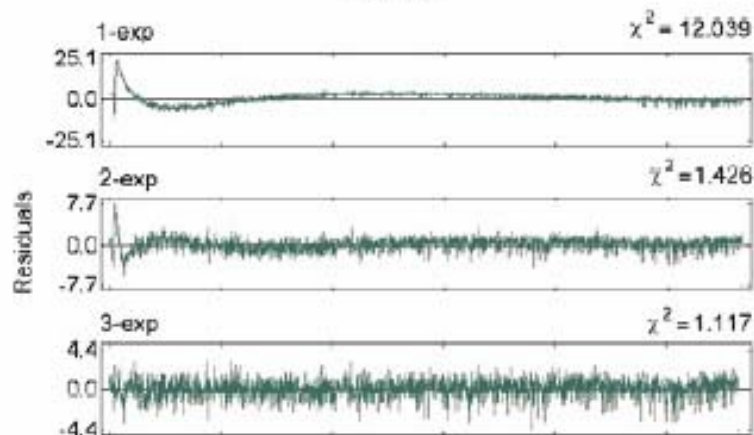
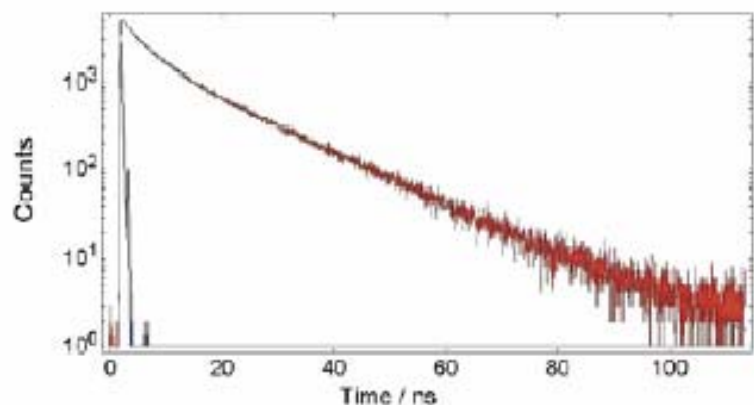

Sample: Hematoporphyrin IX in a phosphate buffer (pH 7.2)

Measurement Conditions: picosecond diode laser, $\lambda_{\text{ex}} = 398\text{nm}$,
rep. rate = 1MHz, MCP-PMT detector, $\lambda_{\text{em}} = 720\text{nm}$

Fit Result: (relative fluorescence contribution in brackets)

$$\tau_1 = 14.80 \pm 0.06 \text{ ns (69.69\%)}$$

$$\tau_2 = 4.62 \pm 0.09 \text{ ns (27.11\%)}$$

$$\tau_3 = 0.81 \pm 0.05 \text{ ns (3.20\%)}$$

- Time Domain vs Frequency Domain

TCSPC

- Excitation by pulse
- Directly measures entire decay behavior
- Improve readings by increasing measurement time

Phase-Modulation

- Intensity modulated excitation
- Phase angle and modulation give two independent measures of lifetime
- Improve readings by measuring more frequencies (10 psec까지도 가능)

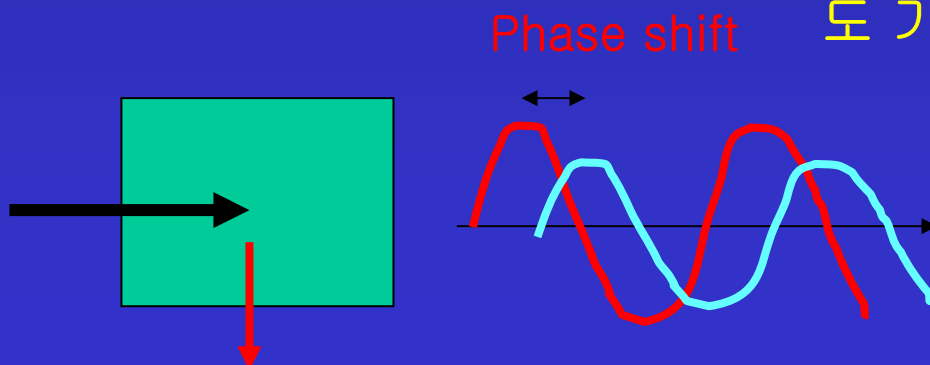

Measuring Fluorescence Lifetime

Time Domain

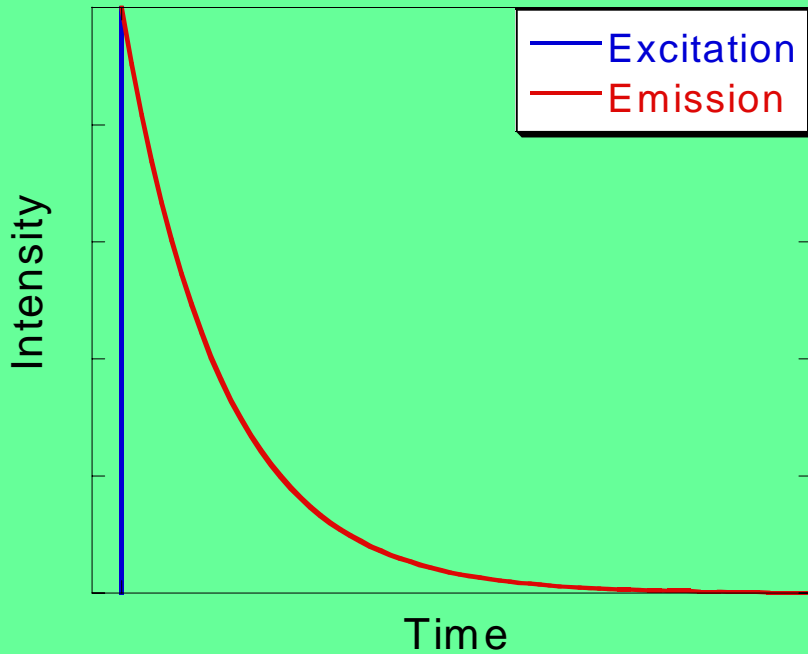

$$I = I_0 e^{-t/\tau}$$

Frequency Domain

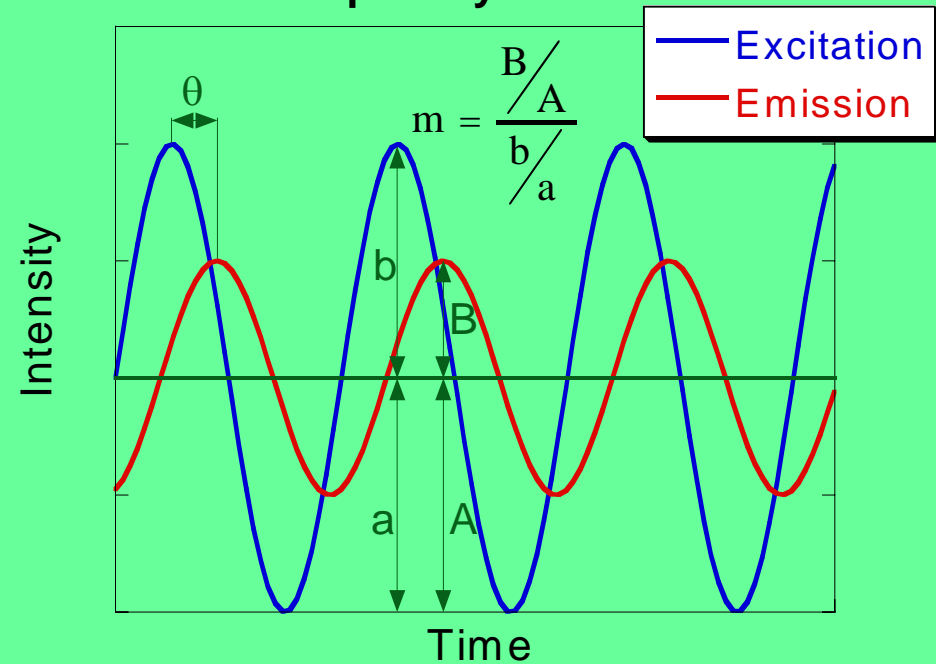

$$\tan \theta = \omega \tau$$

$$m = (1 + \omega^2 \tau^2)^{-1/2}$$

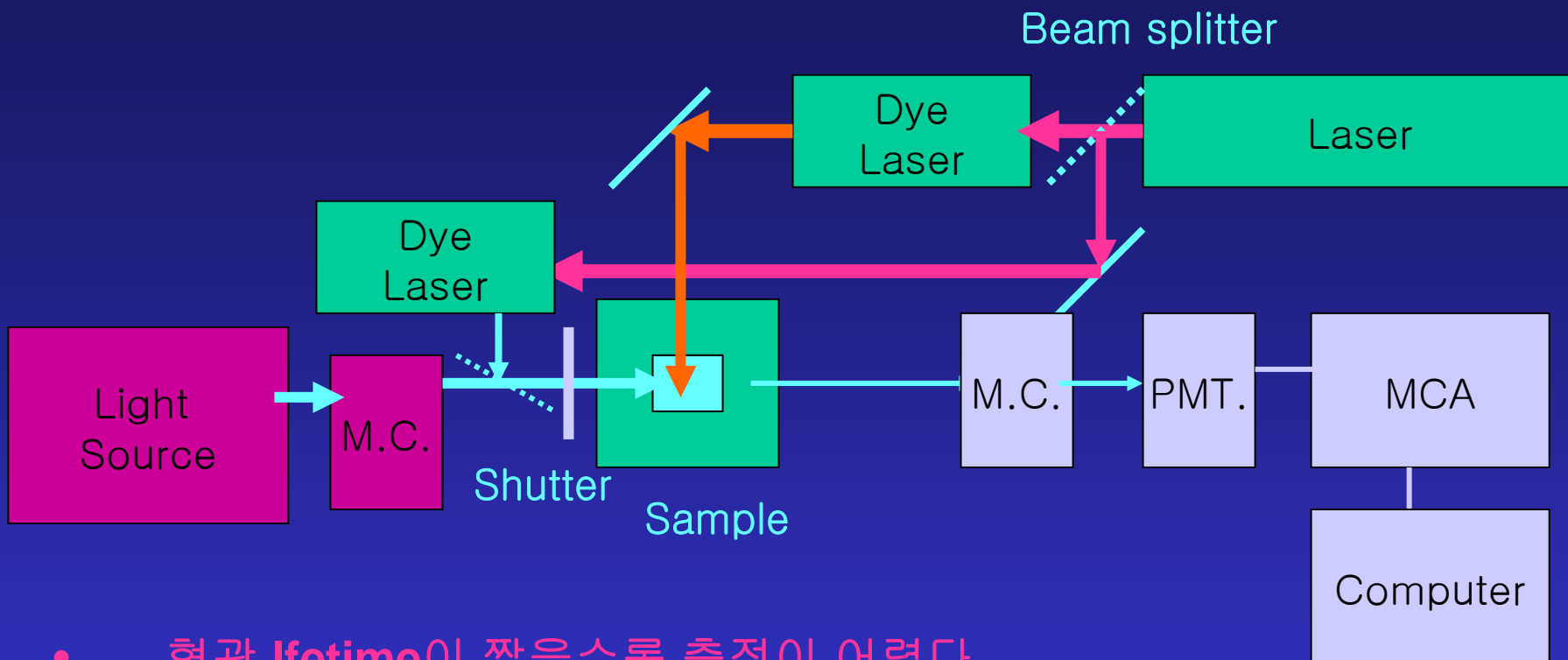

- 형광 lifetime이 짧을수록 측정이 어렵다.

$$\log \frac{I_{no-pump}}{I_{pump}} = A = -\sigma_{exct} N_{exct} l$$

한 파장에서 시간에 대한 광흡수 변화

광흡수 측정의 적정 파장

Laser Pulse

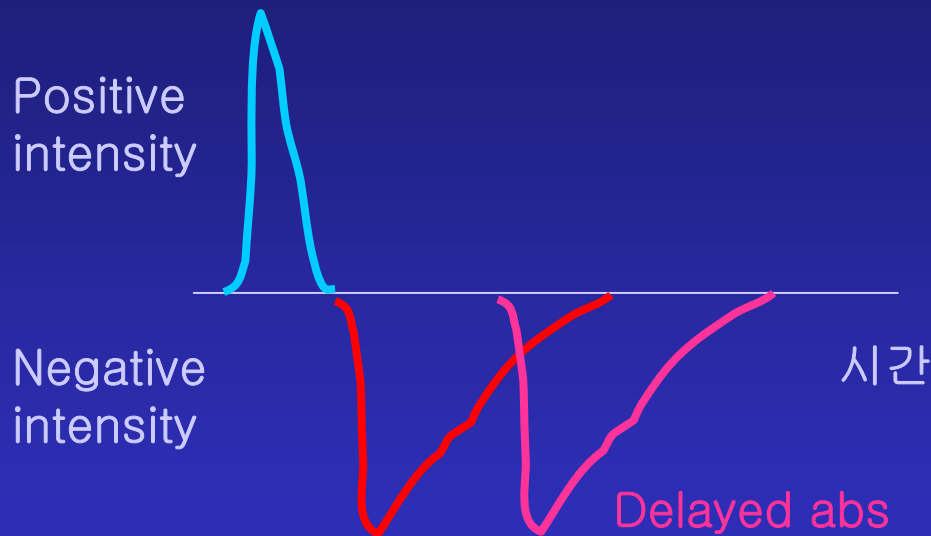

Ground State Absorption

Singlet or Triplet State Absorption

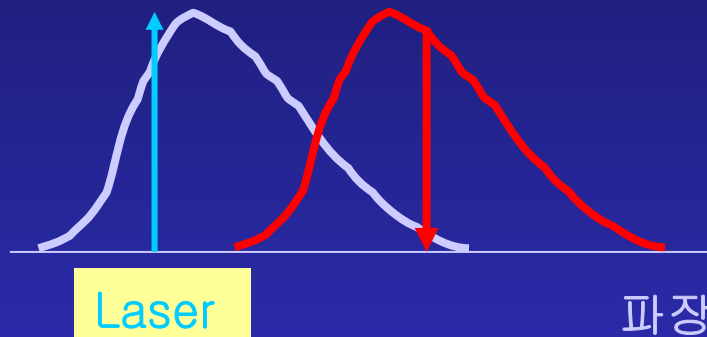

Monitoring the Decay of this Absorption wavelength

1. **Inner filter effect : self absorption**에 의해서 빛의 흡수가 안 되는 경우 (농도가 높은 경우) ; 표면에서 거의 다 흡수
2. **Wavelength effects on Φ : excitation, emission wavelength** 선택 파장이 2배 되는 지점에서 높은 빛 **intensity** 감지.
3. **Refractive index correction**; 차이 나는 곳에서 굴절 및 반사
4. **Polarization effects: grating, light source, condensed phase**
5. **Temperature effects: light source**에서 나온 에너지에 의한 **local heating** -> **ir filter** 사용
6. **Impurity : (~ppm) impurity**의 양이 적어도 형광 Φ 의 상대적인 양이 매우 크면 더 크게 보일 수 있다. 형광 **quenching effects** 등도 문제.
7. **Photochemical stability** : 광 반응성이 좋은 경우 시간 따라 형광의 크기가 달라진다.
8. **Raman scattering**: 작은 입자 (유기 용매에 들어 있는 물, 나노 **crystal**) 들에 의한 **scattering**과 형광과의 구분이 안될 수 있다. 특히 형광의 양이 작은 경우에 .

- **Fluorescence Quantum Yield Measurement**
- **1) Primary Method**

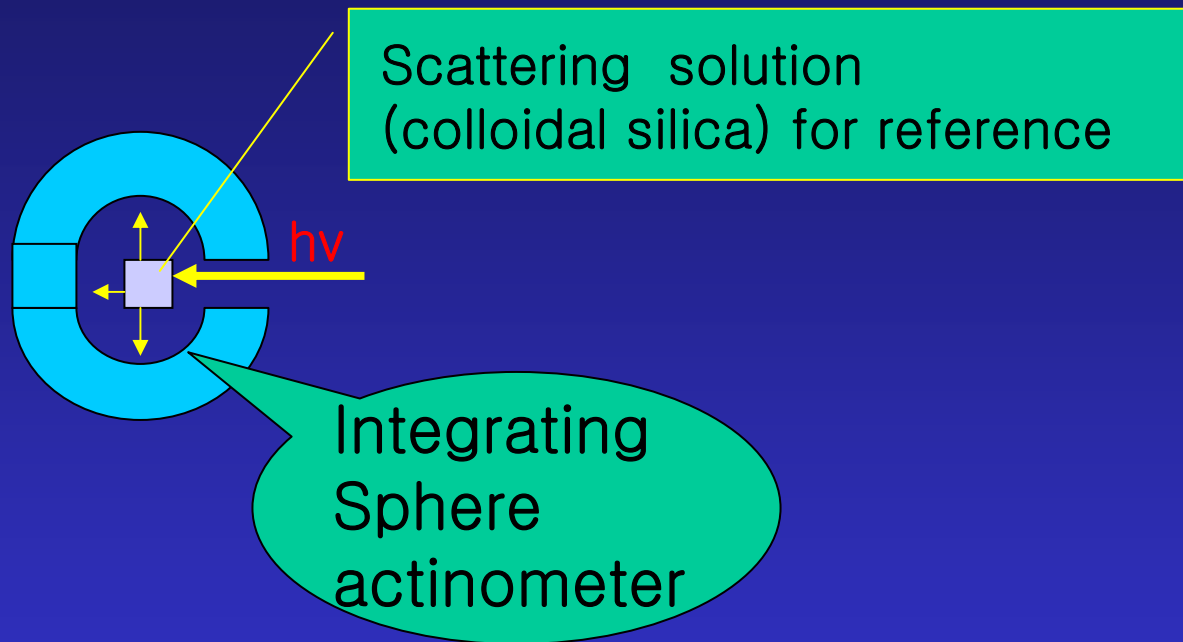

- **Cell에서 나오는 광의 절대적인 양을 *intergrating sphere*를 이용하여 측정한다.**

- **Secondary Method**

$$\frac{\Phi_F^S}{\Phi_F^R} = \frac{\int I_F^S(\bar{\nu}) d\bar{\nu}}{\int I_F^R(\bar{\nu}) d\bar{\nu}} \times \frac{OD_\lambda^R}{OD_\lambda^S} \times \frac{\eta_R^2}{\eta_S^2}$$

- η : refractive index (경계면 반사 및 cell 안에서 internal reflection 문제)

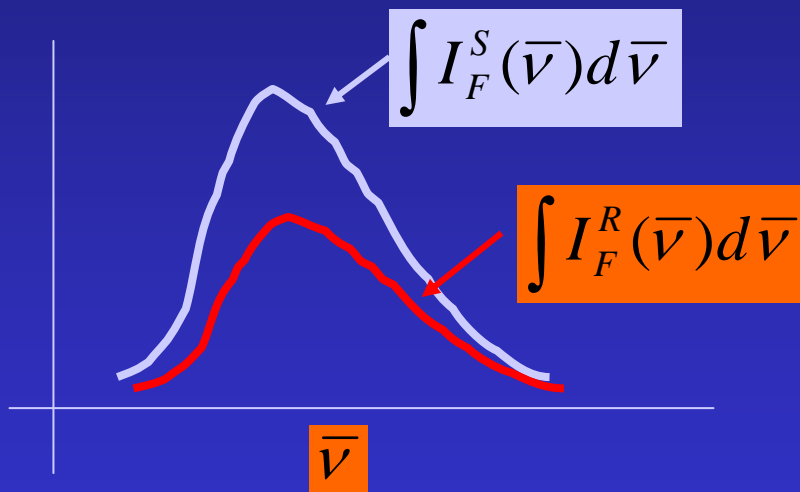

- **고려해야 할 점들**
- **Sample**과 **reference**의 파장 영역이 맞지 않는 경우는 가장 가까운 것을 찾아서 **reference**로 사용한다. 같은 용매를 사용한 경우가 가장 좋고, 형광의 양도 비슷하면 더욱 좋고, 흡수도 등 모든 조건이 유사한 **reference**를 고른다.
- 흡수도가 다른 농도에서 실험하여 흡수도와 형광의 양이 직선적으로 변하는가를 확인한다.
- **Reference** 들을 **cross-calibration** 하여 이들이 맞는지 확인하여야 한다. (**reference**의 **quantum yields**가 틀린 경우가 종종 있다.)
- **실험 방법**
- 1. 흡수 **spectrum**을 얻고 **excitation** 파장에서의 흡수도 기록.
- 2. **10mm cuvette**을 이용하여 완전히 **corrected**된 **spectrum**을 얻은 후 면적 적분. 둘 모두 같은 용매 사용
- 3. **5**개의 다른 농도에서 실험하여 직선 관계 확인 (충분히 낮은 농도에서는 한 농도에서 실험으로 대체)
- 4. **Reference calibration**한 후 비례 관계로 계산.

- 형광의 차이가 아주 많이 나는 경우

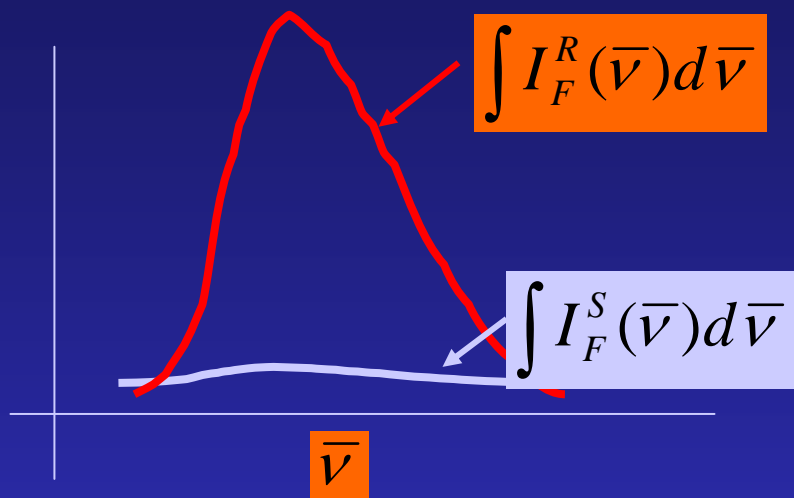

- 1. Reference O.D. 를 낮춘다.
- 2. Quencher를 사용하여 reference의 형광 양을 줄인다. (제일 나중에 사용하는 방법) :

$$\frac{I_0}{I}, \frac{\tau_0}{\tau} \text{로부터 reference의 } \Phi_F \text{를 보정한다.}$$

A Table of Standard Materials and Their Literature Quantum Yield Values

Compound	Solvent	Literature Quantum yield	Emission range / nm	Reference
Cresyl violet	Methanol	0.54	600-650	<i>J. Phys. Chem.</i> , 1979, 83 , 696
Rhodamine 101	Ethanol + 0.01% HCl	1.00	600-650	<i>J. Phys. Chem.</i> , 1980, 84 , 1871
Quinine sulfate	0.1M H ₂ SO ₄	0.54	400-600	<i>J. Phys. Chem.</i> , 1961, 65 , 229
Fluorescein	0.1M NaOH	0.79	500-600	<i>J. Am. Chem. Soc.</i> , 1945, 1099
Norharmane	0.1M H ₂ SO ₄	0.58	400-550	<i>J. Lumin.</i> , 1992, 51 , 269-74
Harmane	0.1M H ₂ SO ₄	0.83	400-550	<i>J. Lumin.</i> , 1992, 51 , 269-74
Harmine	0.1M H ₂ SO ₄	0.45	400-550	<i>J. Lumin.</i> , 1992, 51 , 269-74
2-methylharmane	0.1M H ₂ SO ₄	0.45	400-550	<i>J. Lumin.</i> , 1992, 51 , 269-74
Chlorophyll A	Ether	0.32	600-750	<i>Trans. Faraday Soc.</i> , 1957, 53 , 646-55
Zinc phthalocyanine	1% pyridine in toluene	0.30	660-750	<i>J. Chem. Phys.</i> , 1971, 55 , 4131
Benzene	Cyclohexane	0.05	270-300	<i>J. Phys. Chem.</i> , 1968, 72 , 325
Tryptophan	Water, pH 7.2, 25C	0.14	300-380	<i>J. Phys. Chem.</i> , 1970, 74 , 4480
2-Aminopyridine	0.1M H ₂ SO ₄	0.60	315-480	<i>J. Phys. Chem.</i> , 1968, 72 , 2680
Anthracene	Ethanol	0.27	360-480	<i>J. Phys. Chem.</i> , 1961, 65 , 229
9,10-diphenyl anthracene	Cyclohexane	0.90	400-500	<i>J. Phys. Chem.</i> , 1983, 87 , 83

Photochemical Technique: Quantum Yields for Reactions

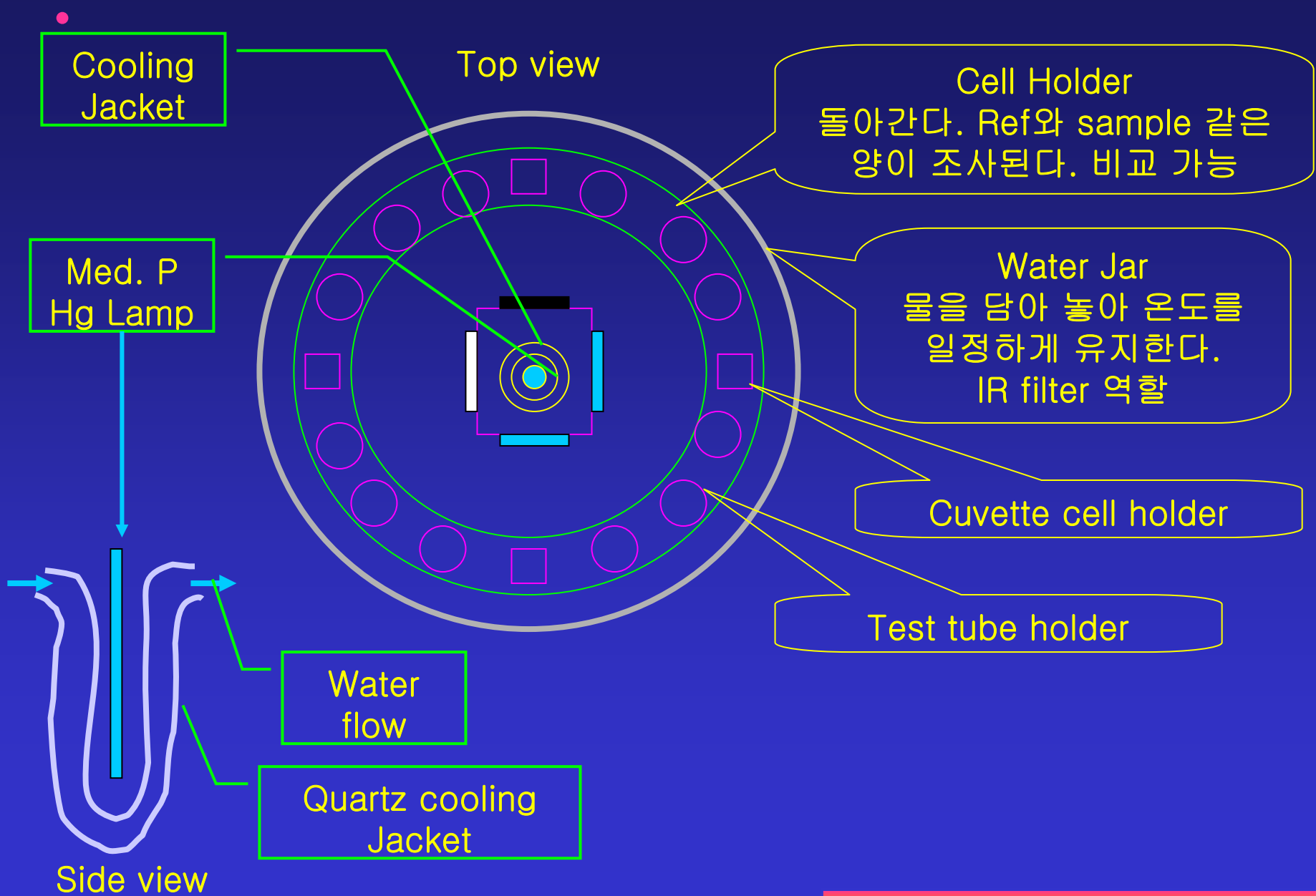

- 간편한 장치

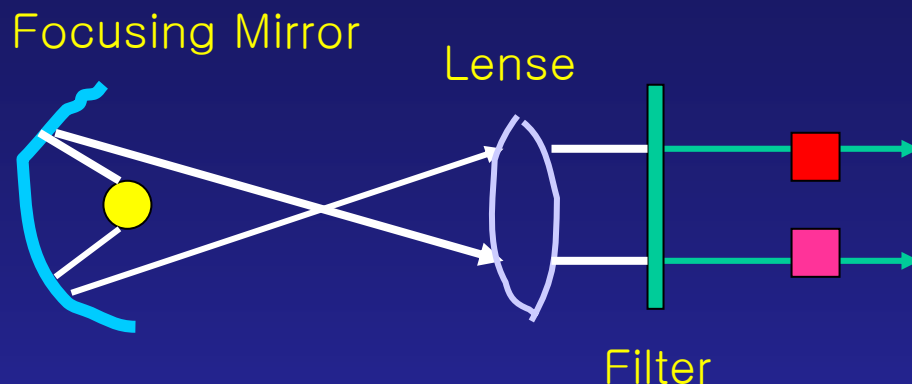

- Lamp 자체의 fluctuation 때문에 reference cell 과 sample cell을 같이 설치하여 측정
- Chemical filter도 dye를 이용하여 사용, 많은 경우 band-path filter 나 특정 파장 이상을 통과하는 filter를 섞어서 사용

- **Potassium Ferrioxalate**

- **Spectral range : 250 ~ 509 nm**



- $\Phi = 1.1 \sim 1.25$

- **436 nm 254nm**

- **1,10-phenanthroline complex**를 만들어서 **510 nm** 에서 **abs**를 측정하여 빛의 강도를 알 수 있다.

- **Ranecke's Salts**

- **Spectral range : 316~600 nm**



- $\Phi = 0.276 \sim 0.388$

- **600 nm 360nm**

- **Cr³⁺ 와 NCS⁻ complex**를 만들어 **450 nm** 에서 흡수도 측정