

CHE302 LECTURE VIII

DYNAMIC BEHAVIORS OF CLOSED-LOOP CONTROL SYSTEMS

Professor Dae Ryook Yang

Fall 2001

Dept. of Chemical and Biological Engineering
Korea University

BLOCK DIAGRAM REPRESENTATION

- Standard block diagram of a feedback control system

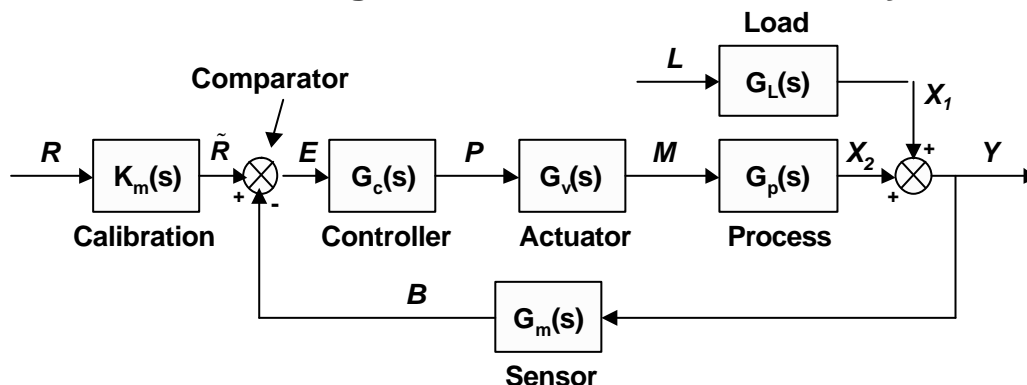

- Process TF: MV (M) effect on CV (X_2 , part of Y)
- Load TF: DV (L) effect on CV (X_1 , part of Y)
- Sensor TF: CV (Y) is transferred to measurement (B)
- Actuator TF: Controller output (P) is transferred to MV (M)
- Controller TF: Controller output (P) is calculated based on error (E)
- Calibration TF: Gain of sensor TF, used to match the actual var.

- **Individual TF of the standard block diagram**

- TF of each block between input and output of that block
- Each gain will have different unit.

- [Example] Sensor TF
- Input range: 0-50 l/min
- Output range: 4-20 mA

$$\text{Gain, } K_m = \frac{20-4}{50-0} = 0.32 \text{ [mA/(l/min)]}$$

- Dynamics: usually 1st order with small time constant

$$G_m(s) = \frac{K_m}{t_m s + 1}$$

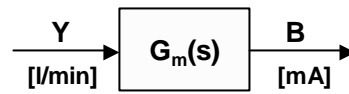

- **Block diagram shows the flow of signal and the connections**
- **Schematic diagram shows the physical components connection**

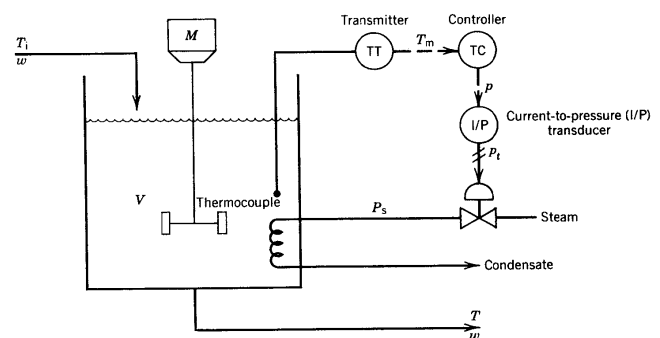
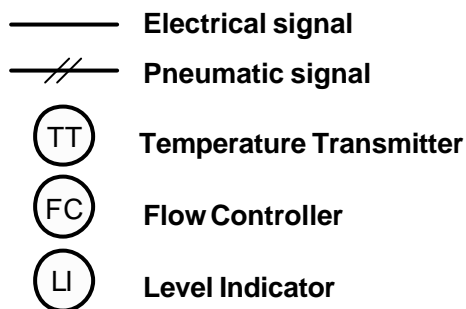

P&ID

- **Piping and Instrumentation diagram**

- A P&ID is a blueprint, or map, of a process.
- Technicians use P&IDs the same way an architect uses blueprints.
- A P&ID shows each of the instruments in a process , their functions, their relationship to other components in the system.
- Most diagrams use a standard format, such as the one developed by ISA (Instrumental Society of America) or SAMA (Scientific Apparatus Makers Association).

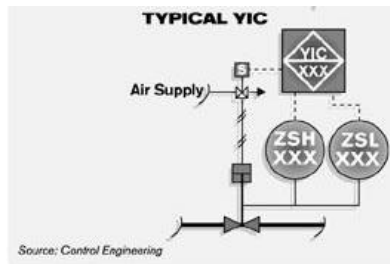
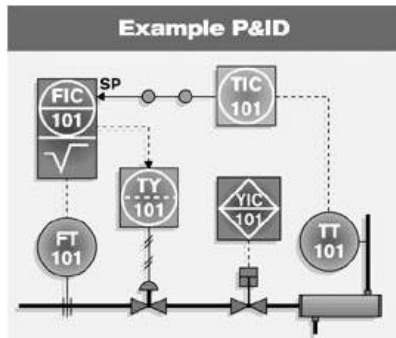

Common connecting lines	
Connection to process, or instrument supply:	
Pneumatic signal:	
Electric signal:	
Capillary tubing (filled system):	
Hydraulic signal:	
Electromagnetic or sonic signal (guided):	
Internal system link (software or data link):	
Source: Control Engineering with data from ISA S5.1 standard	

General instrument or function symbols			
	Primary location accessible to operator	Field mounted	Auxiliary location accessible to operator
Discrete instruments	1	2	3
Shared display, shared control	4	5	6
Computer function	7	8	9
Programmable logic control	10	11	12
1. Symbol size may vary according to the user's needs and the type of document. 2. Abbreviations of the user's choice may be used when necessary to specify location. 3. Inaccessible (behind the panel) devices may be depicted using the same symbol but with a dashed horizontal bar. Source: Control Engineering with data from ISA S5.1 standard			

Identification letters					
	First letter		Succeeding letters		
	Measured or initiating var.	Modifier	Readout or passive func.	Output function	Modifier
A	Analysis		Alarm		
B	Burner, combustion		User's choice	User's choice	User's choice
C	User's choice			Control	
D	User's choice	Differential			
E	Voltage		Sensor (primary element)		
F	Flowrate	Ration (fraction)			
G	User's choice		Glass, viewing device		
H	Hand				High
I	Current (electrical)		Indication		
J	Power	Scan			
K	Time, time schedule	Time rate of change		Control station	
L	Level		Light		Low
M	User's choice	Momentary			Middle, intern.
N	User's choice		User's choice	User's choice	User's choice
O	User's choice		Orifice, restriction		
P	Pressure, vacuum		Point (test connection)		
Q	Quantity	Integrate, totalizer			
R	Radiation		Record		
S	Speed, frequency	Safety		Switch	
T	Temperature			Transmit	
U	Multivariable		Multifunction	Multifunction	Multifunction
V	Vibration, mechanical analysis			Valve, damper, louver	
W	Weight, force		Well		
X	Unclassified	X axis	Unclassified	Unclassified	Unclassified
Y	Event, state, or presence	Y axis		Relay, compute, convert	
Z	Position, dimension	Z axis		Driver, actuator	

Source: Control Engineering with data from ISA S5.1 standard

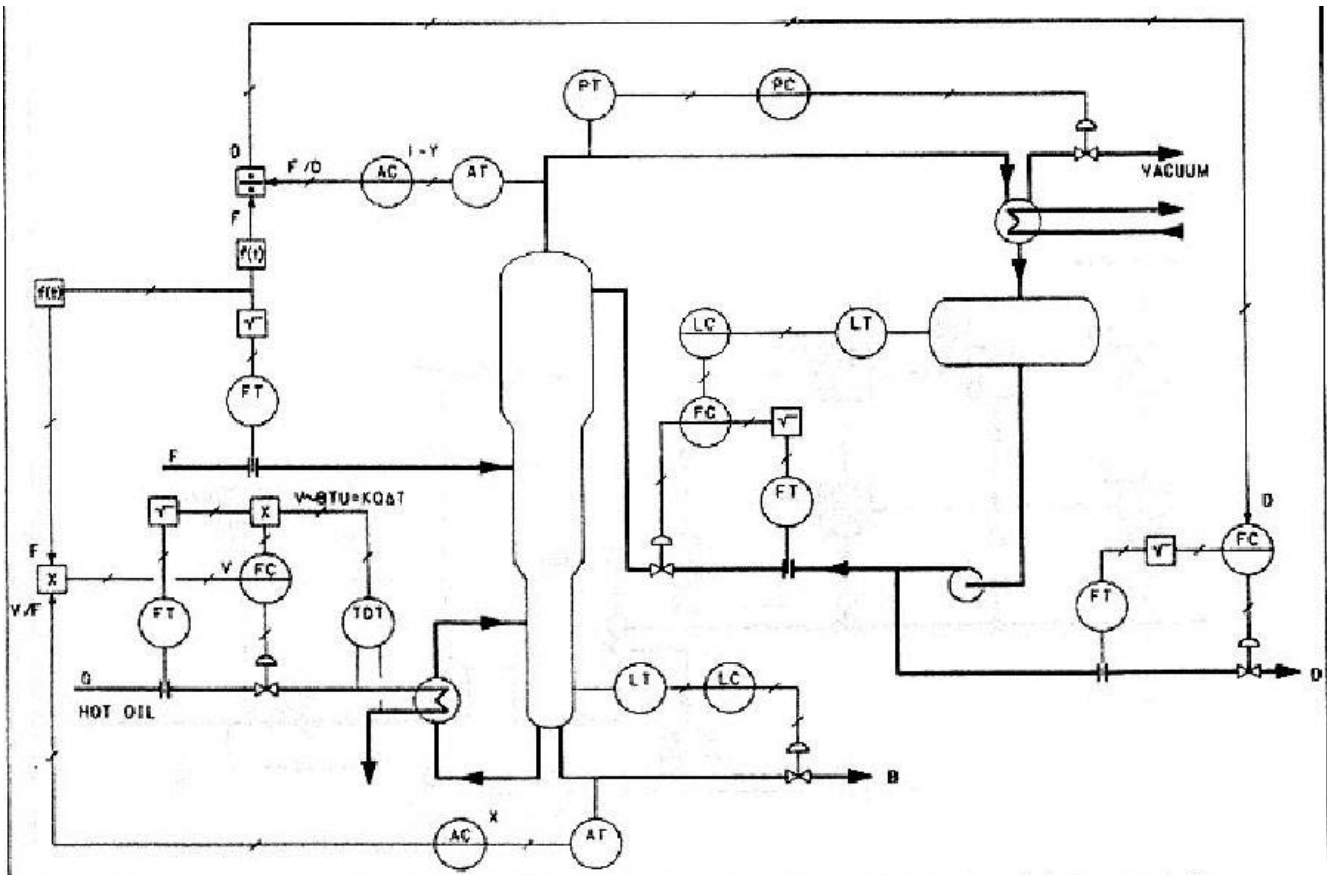

6.3 GENERAL INSTRUMENT OR FUNCTION SYMBOLS (Contd.)

13	14 INSTRUMENT WITH LONG TAG NUMBER	15 INSTRUMENTS SHARING COMMON HOUSING *
16 PILOT LIGHT	17 PANEL MOUNTED PATCHBOARD POINT 12	18 PURGE OR FLUSHING DEVICE **
19 RESET FOR LATCH-TYPE ACTUATOR **	20 DIAPHRAGM SEAL	21 UNDEFINED INTERLOCK LOGIC ***

- * It is not mandatory to show a common housing.
- ** These diamonds are approximately half the size of the larger ones.
- *** For specific logic symbols, see ANSI/ISA Standard 55.2.

6.4 CONTROL VALVE BODY SYMBOLS, DAMPER SYMBOLS

1 GENERAL SYMBOL	2 ANGLE	3 BUTTERFLY	4 ROTARY VALVE
5 THREE-WAY	6 FOUR-WAY	7 GLOBE	8
9 DIAPHRAGM	10 DAMPER OR LOUVER	11 DAMPER OR LOUVER	12 DAMPER OR LOUVER

Further information may be added adjacent to the body symbol either by note or code number.

6.5 ACTUATOR SYMBOLS

1 WITH OR WITHOUT POSITIONER OR OTHER PILOT	2 PREFERRED FOR DIAPHRAGM ASSEMBLED WITH PILOT * ASSEMBLY IS ACTUATED BY ONE INPUT (SHOWN TYPICALLY WITH ELECTRIC INPUT)	3 PREFERRED ALTERNATIVE	4 OPTIONAL ALTERNATIVE
DIAPHRAGM, SPRING-OPOSED OR UNSPECIFIED ACTUATOR		DIAPHRAGM, SPRING-OPOSED, WITH POSITIONER ** AND OVERRIDING PILOT VALVE THAT PRESSURIZES DIAPHRAGM WHEN ACTUATED	
5 DIAPHRAGM, PRESSURE-BALANCED	6 ROTARY MOTOR (SHOWN TYPICALLY WITH ELECTRIC SIGNAL, MAY BE HYDRAULIC OR PNEUMATIC)	7 DIGITAL	
8 SPRING-OPOSED SINGLE-ACTING	9 DOUBLE-ACTING	10 PREFERRED FOR ANY CYLINDER THAT IS ASSEMBLED WITH A PILOT * SO THAT ASSEMBLY IS ACTUATED BY ONE CONTROLLED INPUT	
CYLINDER, WITHOUT POSITIONER OR OTHER PILOT			

CLOSED LOOP TRANSFER FUNCTION

- Block diagram algebra

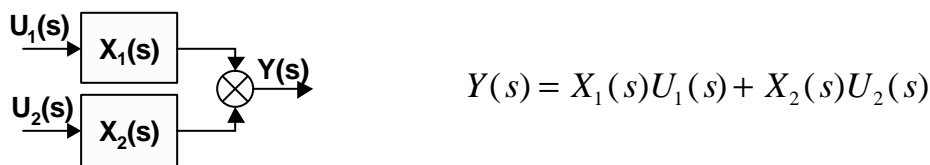
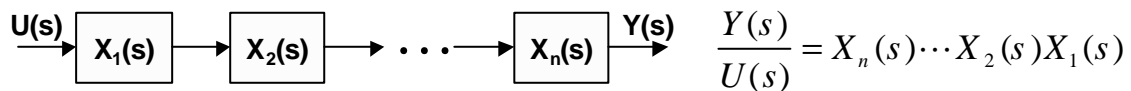

- Transfer functions of closed-loop system

$$X_2(s) = G_p(s)G_v(s)G_c(s)E(s) \quad E(s) = K_m(s)R(s) - G_m(s)Y(s)$$

$$Y(s) = G_L(s)L(s) + X_2(s) \implies Y(s) = G_L(s)L(s) + G_p(s)G_v(s)G_c(s)E(s)$$

$$\implies Y(s) = G_L(s)L(s) + G_p(s)G_v(s)G_c(s)(K_m(s)R(s) - G_m(s)Y(s))$$

$$\longrightarrow (1 + G_m(s)G_p(s)G_v(s)G_c(s))Y(s) = G_L(s)L(s) + K_m G_p(s)G_v(s)G_c(s)R(s)$$

- **For set-point change (L=0)**

$$\frac{Y(s)}{R(s)} = \frac{K_m G_p(s) G_v(s) G_c(s)}{1 + G_m(s) G_p(s) G_v(s) G_c(s)}$$

- **For load change (R=0)**

$$\frac{Y(s)}{L(s)} = \frac{G_L(s)}{1 + G_m(s) G_p(s) G_v(s) G_c(s)}$$

- **Open-loop transfer function (G_{OL})**

$$G_{OL}(s) \triangleq G_m(s) G_p(s) G_v(s) G_c(s)$$

- **Feedforward path:** Path with no connection backward
- **Feedback path:** Path with circular connection loop
- G_{OL} : feedback loop is broken before the comparator

- **Simultaneous change of set point and load**

$$Y(s) = \frac{K_m G_p(s) G_v(s) G_c(s)}{1 + G_{OL}(s)} R(s) + \frac{G_L(s)}{1 + G_{OL}(s)} L(s)$$

MASON'S RULE

- **General expression for feedback control systems**

$$\frac{Y}{X} = \frac{p_f}{1 + p_e}$$

$p_f \equiv$ product of the transfer function in the path from X to Y

$p_e \equiv$ product of all transfer function in the entire feedback loop

- **Assume feedback loop has negative feedback.**
- **If it has positive feedback, $1 + p_e$ should be $1 - p_e$.**
- **In the previous example, for set-point change**

$$X = R \quad Y = Y \quad p_f = K_m G_c(s) G_v(s) G_p(s) \quad p_e = G_{OL}(s)$$

$$\frac{Y(s)}{R(s)} = \frac{K_m G_p(s) G_v(s) G_c(s)}{1 + G_{OL}(s)}$$

- **For load change, $X = L \quad Y = Y \quad p_f = G_L(s) \quad p_e = G_{OL}(s)$**

• **Example 1**

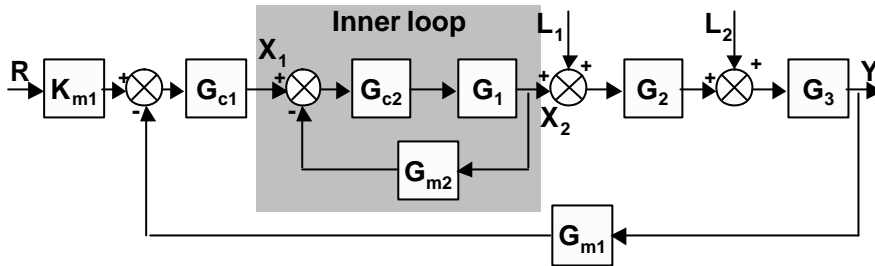

– **Inner loop:** $X_2 = \frac{G_1 G_{c2}}{1 + G_{m2} G_1 G_{c2}} X_1$

– **TF between R and Y:**

$$p_f = K_{m1} G_3 G_2 \frac{G_1 G_{c2}}{1 + G_{m2} G_1 G_{c2}} G_{c1} \quad p_e = G_{m1} G_3 G_2 \frac{G_1 G_{c2}}{1 + G_{m2} G_1 G_{c2}} G_{c1}$$

$$\frac{Y}{R} = \frac{K_{m1} G_3 G_2 G_1 G_{c2} G_{c1}}{1 + G_{m2} G_1 G_{c2} + G_{m1} G_3 G_2 G_1 G_{c2} G_{c1}}$$

– **TF between L₁ and Y:**

$$\frac{Y}{L_1} = \frac{G_3 G_2}{1 + G_{m2} G_1 G_{c2} + G_{m1} G_3 G_2 G_1 G_{c2} G_{c1}}$$

• **Example 2**

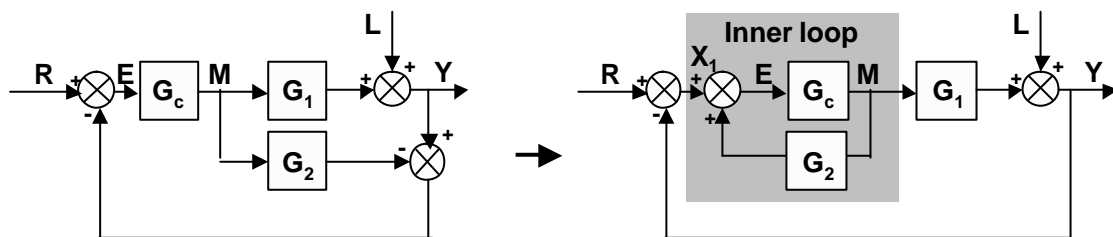

$$E = R - (G_1 - G_2)M = R - G_1 M + G_2 M$$

– **Inner loop:** $M = \frac{G_c}{1 - G_2 G_c} X_1$

– **TF between R and Y:**

$$p_f = \frac{G_c}{1 - G_2 G_c} G_1 \quad p_e = \frac{G_c}{1 - G_2 G_c} G_1$$

$$\frac{Y}{R} = \frac{G_1 G_c}{1 - G_2 G_c + G_1 G_c} = \frac{G_1 G_c}{1 + (G_1 - G_2) G_c}$$

– **TF between L and Y:** $\frac{Y}{L} = \frac{1 - G_2 G_c}{1 - G_2 G_c + G_1 G_c} = \frac{1 - G_2 G_c}{1 + (G_1 - G_2) G_c}$

PID CONTROLLER REVISITED

- **P control**

$$p(t) = \bar{p} + K_c e(t) \xrightarrow{\mathcal{L}} \frac{P(s)}{E(s)} = K_c$$

- **PI control**

$$p(t) = \bar{p} + K_c \left\{ e(t) + \frac{1}{t_I} \int_0^t e(t) dt \right\} \xrightarrow{\mathcal{L}} \frac{P(s)}{E(s)} = K_c \left(1 + \frac{1}{t_I s} \right) = K_c \frac{(t_I s + 1)}{t_I s}$$

- **PID control**

$$p(t) = \bar{p} + K_c \left\{ e(t) + \frac{1}{t_I} \int_0^t e(t) dt + t_D \frac{de}{dt} \right\} \xrightarrow{\mathcal{L}}$$

$$\frac{P(s)}{E(s)} = K_c \left(1 + \frac{1}{t_I s} + t_D s \right) = K_c \frac{(t_I t_D s^2 + t_I s + 1)}{t_I s}$$

- **Ideal PID controller: Physically unrealizable**
- **Modified form has to be used.**

- **Nonideal PID controller**

- **Interacting type**

$$G_c^*(s) = K_c^* \frac{(t_I^* s + 1)}{t_I^* s} \frac{(t_D^* s + 1)}{(b t_D^* s + 1)} \quad (0 < b \ll 1)$$

← Filtering effect

- **Comparison with ideal PID except filter**

$$G_c(s) = K_c \frac{(t_I t_D s^2 + t_I s + 1)}{t_I s}$$

$$K_c^* \frac{(t_D^* t_I^* s^2 + (t_I^* + t_D^*) s + 1)}{t_I^* s} = \frac{K_c^* (t_I^* + t_D^*)}{t_I^*} \left(1 + \frac{1}{(t_I^* + t_D^*) s} + \frac{t_D^* t_I^*}{(t_I^* + t_D^*) s} \right)$$

$$K_c = \frac{K_c^* (t_I^* + t_D^*)}{t_I^*}, \quad t_I = t_I^* + t_D^*, \quad t_D = \frac{t_D^* t_I^*}{(t_I^* + t_D^*)}$$

- **These types are physically realizable and the modification provides the prefiltering of the error signal.**
- **Generally, $t_I \geq t_D$ and typically $t_I \approx 4t_D$.**
- **In this form, $t_I \geq t_D$ is satisfied automatically since algebraic mean is not less than logarithm mean.**

- **Block diagram of PID controller**

- **Nonideal interacting type PID**

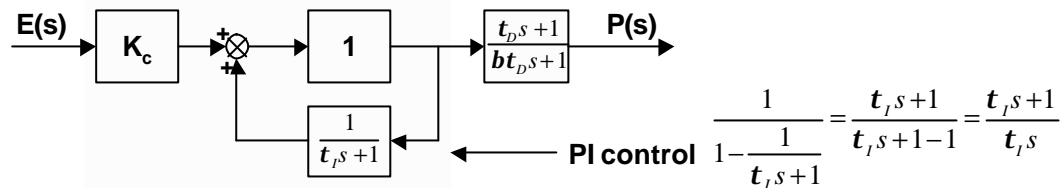

$$P(s) = K_c \frac{(t_I s + 1)}{t_I s} \frac{(t_D s + 1)}{(b t_D s + 1)} E(s)$$

- **Removal of derivative kick (PI-D controller)**

$$P(s) = K_c \left[\frac{(t_I s + 1)}{t_I s} \frac{(t_D s + 1)}{(b t_D s + 1)} Y(s) - \frac{(t_I s + 1)}{t_I s} R(s) \right]$$

- **Removal of both P & D kicks (I-PD controller)**

$$P(s) = K_c \left[\frac{(t_I s + 1)}{t_I s} \frac{(t_D s + 1)}{(b t_D s + 1)} Y(s) - \frac{1}{t_I s} R(s) \right]$$

- **Other variations of PID controller**

- **Gain scheduling : modifying proportional gain**

$$K_c^{GS} = K_c K^{GS}$$

where

$$1. K^{GS} = \begin{cases} K_{Gap} & \text{for (lower gap)} \leq e(t) \leq \text{(upper gap)} \\ 1 & \text{otherwise} \end{cases}$$

$$2. K^{GS} = 1 + C_{GS} |e(t)|$$

3. K^{GS} is decided based on some strategy

- **Nonlinear PID controller**

- **Replace $e(t)$ with $e(t) |e(t)|$.**
- **Sign of error will be preserved but small error gets smaller and larger error gets larger.**
- **It imposes less action for a small error.**

DIGITAL PID CONTROLLER

- **Discrete time system**

- Measurements and actions are taken at every sampling interval.
- An action will be hold during the sampling interval.

- **Digital PID controller**

- **using** $\int_0^{t_n} e(t)dt = \Delta t \sum_{i=0}^n e(t_i)$ (Rectangular rule)

$$\frac{de(t)}{dt} = \frac{e(t_n) - e(t_{n-1})}{\Delta t} \quad (\text{Backward difference approx.})$$

$$p(t_n) = \bar{p} + K_c \left[e(t_n) + \frac{\Delta t}{t_I} \sum_{i=0}^n e(t_i) + t_D \frac{e(t_n) - e(t_{n-1})}{\Delta t} \right] \quad (\text{Position form})$$

$$\Delta p(t_n) = p(t_n) - p(t_{n-1})$$

$$= K_c \left[e(t_n) - e(t_{n-1}) + \frac{\Delta t}{t_I} e(t_n) + t_D \frac{e(t_n) - 2e(t_{n-1}) + e(t_{n-2}))}{\Delta t} \right] \quad (\text{Velocity form})$$

- Most modern PID controllers are manufactured in digital form with short sampling time.
- If the sampling time is small, there is not much difference between continuous and digital forms.
- Velocity form does not have reset windup problem because there is no summation (integration).
- Other approximation such as trapezoidal rule and etc. can be used to enhance the accuracy. But the improvement is not substantial.

$$\int_0^{t_n} e(t)dt = \Delta t \sum_{i=1}^n \frac{e(t_i) + e(t_{i-1}))}{2} \quad (\text{Trapezoidal rule})$$

$$\frac{de(t)}{dt} = \frac{e(t_n) + 3e(t_{n-1}) - 3e(t_{n-2}) - e(t_{n-3}))}{\Delta t} \quad (\text{Interpolation formula})$$

- **For discrete time system, z-transform is the counterpart of Laplace transform. (out of scope of this lecture)**

CLOSED-LOOP RESPONSE OF 1ST ORDER SYSTEM

- Process**

$$rA \frac{dh}{dt} = rq_1 + rq_2 - r \frac{h}{R}$$

$$G_p(s) = \frac{H(s)}{Q_2(s)} = \frac{R}{RA s + 1} = \frac{K_p}{t s + 1}$$

$$G_L(s) = \frac{H(s)}{Q_1(s)} = \frac{R}{RA s + 1} = \frac{K_p}{t s + 1}$$

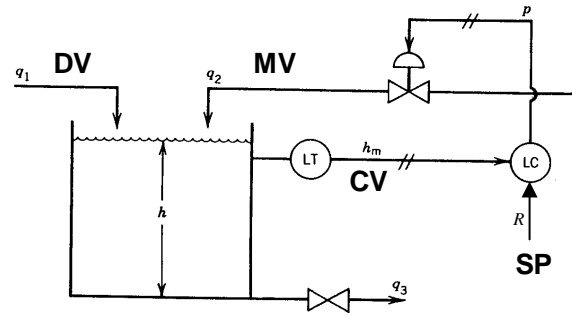

- **Assume**

Sensor and actuator dynamics are fast enough to be ignored and gains are lumped in other TF.

$$G_v(s) = G_m(s) = 1$$

$$H(s) = \frac{G_c G_p}{1 + G_c G_p} R(s) + \frac{G_L}{1 + G_c G_p} L(s)$$

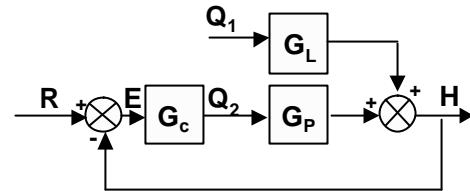

- P control for set-point change (L=0)**

$$G_c(s) = K_c \quad (K_c > 0)$$

$$G_{CL}(s) = \frac{H(s)}{R(s)} = \frac{K_c K_p / (t s + 1)}{1 + K_c K_p / (t s + 1)} = \frac{K_c K_p / (1 + K_c K_p)}{(t / (1 + K_c K_p)) s + 1} \quad (\text{closed-loop TF})$$

- **Closed-loop gain and time constant**

$$K_{CL} = \frac{K_c K_p}{(1 + K_c K_p)}, \quad t_{CL} = \frac{t}{(1 + K_c K_p)}$$

- **Steady-state behavior of closed-loop system**

$$K_{CL} = \frac{K_c K_p}{(1 + K_c K_p)} < 1, \quad \lim_{K_c \rightarrow \infty} G_{CL} = 1 \quad (H(s) = R(s), \text{ no offset})$$

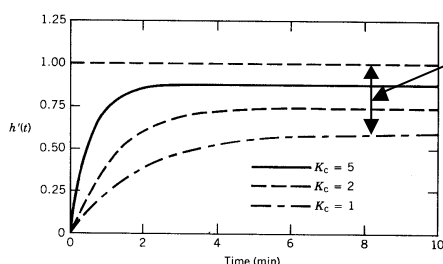

Steady-state offset = $r(\infty) - h(\infty) = 1 - K_{CL} = \frac{1}{1 + K_c K_p}$

Closed-loop response will not reach to set point (offset)

Infinite controller gain will eliminate the offset

Higher controller gain results faster closed-loop response: shorter time constant

- **P control for load change (R=0)**

$$G_c(s) = K_c \quad (K_c > 0)$$

$$G_{CL}(s) = \frac{H(s)}{L(s)} = \frac{K_p/(ts+1)}{1+K_c K_p/(ts+1)} = \frac{K_p/(1+K_c K_p)}{(t/(1+K_c K_p))s+1} \quad (\text{closed-loop TF})$$

– **Closed-loop gain and time constant**

$$K_{CL} = \frac{K_p}{(1+K_c K_p)}, \quad t_{CL} = \frac{t}{(1+K_c K_p)}$$

– **Steady-state behavior of closed-loop system**

$$K_{CL} = \frac{K_p}{(1+K_c K_p)} > 0, \quad \lim_{K_c \rightarrow \infty} G_{CL} = 0 \quad (\text{disturbance is compensated})$$

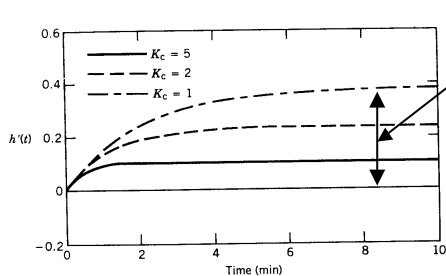

$$\text{Steady-state offset} = 0 - h(\infty) = 0 - K_{CL} = -\frac{K_p}{1+K_c K_p}$$

Disturbance effect will not be eliminated completely (offset)

Infinite controller gain will eliminate the offset

Higher controller gain results faster closed-loop response: shorter time constant

- **PI control for load change (R=0)**

$$G_c(s) = K_c(t_I s + 1)/t_I s \quad (K_c > 0)$$

$$G_{CL}(s) = \frac{K_p/(ts+1)}{1+K_c K_p(t_I s + 1)/(ts+1)/t_I s} = \frac{K_p t_I s}{t_I t s^2 + t_I(1+K_c K_p)s + K_c K_p}$$

– **Closed-loop gain, time constant, damping coefficient**

$$K_{CL} = \frac{t_I}{K_c}, \quad t_{CL} = \sqrt{\frac{t t_I}{K_c K_p}}, \quad z_{CL} = \frac{1}{2} \frac{(1+K_c K_p)}{\sqrt{K_c K_p}} \sqrt{t_I/t}$$

– **Steady-state behavior of closed-loop system**

$$\lim_{s \rightarrow 0} G_{CL}(s) = 0 \quad (\text{disturbance is compensated for all cases})$$

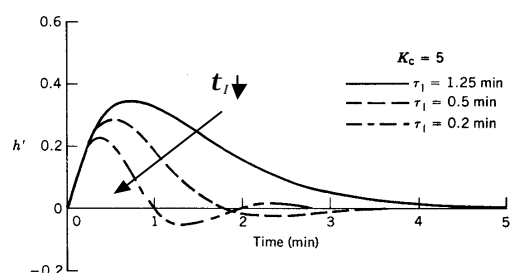
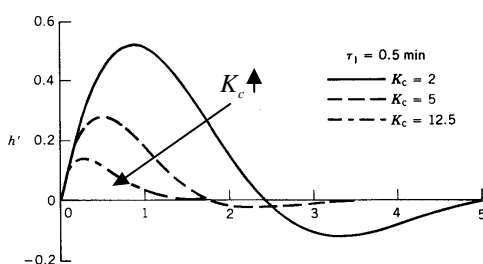

- As K_c increases, faster compensation of disturbance and less oscillatory response can be achieved.
- As t_I decreases, faster compensation of disturbance and less overshooting response can be achieved.
- However, usually the response gets more oscillation as K_c increases or t_I decreases. => very unusual!!
- If there is small lag in sensor/actuator TF or time delay in process TF, the system becomes higher order and these anomalous results will not occur. These results is only possible for very simple process such as 1st order system.
- Usual effect of PID tuning parameters
 - As K_c increases, the response will be faster, more oscillatory.
 - As t_I decreases, the response will be faster, more oscillatory.
 - As t_D increases, the response will be faster, less oscillatory when there is no noise.

CLOSED-LOOP RESPONSE OF INTEGRATING SYSTEM

• Process

$$rA \frac{dh}{dt} = r(q_1 + q_2) - r q_3$$

$$G_p(s) = \frac{H(s)}{Q_3(s)} = -\frac{1}{As}$$

$$G_L(s) = \frac{H(s)}{Q_1(s)} = \frac{1}{As}$$

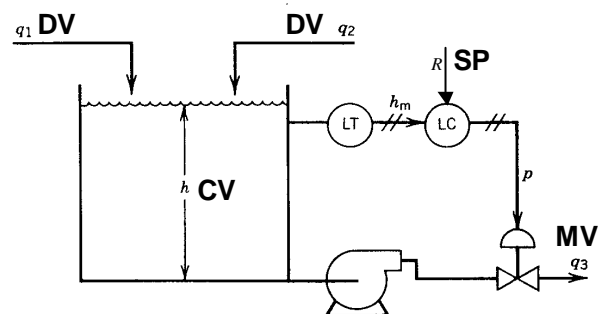

- Assume

Sensor and actuator dynamics are fast enough to be ignored and gains are lumped in other TF.

$$G_v(s) = G_m(s) = 1$$

$$H(s) = \frac{G_c G_p}{1 + G_c G_p} R(s) + \frac{G_L}{1 + G_c G_p} L(s)$$

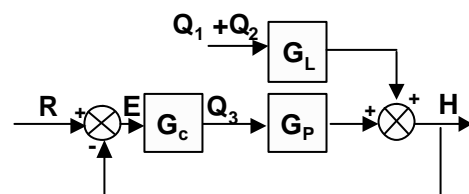

- **P control for set-point change (L=0)**

$$G_c(s) = K_c \quad (K_c < 0)$$

$$G_{CL}(s) = \frac{H(s)}{R(s)} = \frac{K_c / (-As)}{1 + K_c / (-As)} = \frac{1}{(-A / K_c) s + 1} \quad (\text{closed-loop TF})$$

- **Closed-loop gain and time constant**

$$K_{CL} = 1, \quad t_{CL} = -A / K_c$$

- **Steady-state behavior of closed-loop system**

$$K_{CL} = 1 \quad (H(s) = R(s), \text{ no offset even with p control})$$

- **It is very unique that the integrating system will not have offset even with P control for the set point change.**
- **Even though there are other dynamics in sensor or actuator, the offset will not be shown with P control for integrating systems.**
- **Higher controller gain results faster closed-loop response: shorter time constant**

- **P control for load change (R=0)**

$$G_c(s) = K_c \quad (K_c < 0)$$

$$G_{CL}(s) = \frac{H(s)}{L(s)} = \frac{1 / (As)}{1 + K_c / (-As)} = \frac{-1 / K_c}{(-A / K_c) s + 1} \quad (\text{closed-loop TF})$$

- **Closed-loop gain and time constant**

$$K_{CL} = (-1 / K_c), \quad t_{CL} = -A / K_c$$

- **Steady-state behavior of closed-loop system**

$$K_{CL} = \frac{1}{(-K_c)} > 0, \quad \lim_{K_c \rightarrow \infty} G_{CL} = 0 \quad (\text{disturbance is compensated})$$

- **Higher controller gain results faster closed-loop response: shorter time constant**

- **PI control for set-point change (L=0)**

$$G_c(s) = K_c(t_I s + 1)/t_I s \quad (K_c < 0)$$

$$G_{CL}(s) = \frac{K_c(t_I s + 1)/(-As)/t_I s}{1 + K_c(t_I s + 1)/(-As)/t_I s} = \frac{(t_I s + 1)}{(-t_I A / K_c)s^2 + t_I s + 1}$$

- **Closed-loop gain, time constant, damping coefficient**

$$K_{CL} = 1, \quad t_{CL} = \sqrt{-\frac{t_I A}{K_c}}, \quad z_{CL} = \frac{1}{2} \sqrt{-\frac{t_I K_c}{A}}$$

- **Steady-state behavior of closed-loop system**

$$K_{CL} = \lim_{s \rightarrow 0} G_{CL}(s) = 1 \quad (H(s) = R(s), \text{ no offset})$$

- **As $(-K_c)$ increases, closed-loop time constant gets smaller (faster response) and less oscillatory response can be achieved.**
- **As t_I decreases, closed-loop time constant gets smaller (faster response) and more oscillatory response can be achieved.**
- **Partly anomalous results due to integrating nature**
- **For integrating system, the effect of tuning parameters can be different. Thus, rules of thumb cannot be applied blindly.**